

ZOOMLION SCISSOR LIFTS AC SERIES

Comply with CE/ANSI/CSA Standard

HIGHLIGHTS

High Performance

- ▶ AC system offers higher working efficiency
- ▶ IP67 rated waterproof protection on AC wheel motors for longer lifespan

Cost Effectiveness

- ▶ Knuckles lubrication-free and maintenance-free
- ▶ AC motor full lifecycle maintenance-free
- ▶ Swing-out tray easy to service

FEATURES

Standard Features

Proportional controls	Active pothole protection system
AI motion alarm	Drivable at full height
Fold-down handrails	Hour meter
Flashing beacon	Extension deck (unidirectional)
Self-closing entry gate	Charging protection system
Autobrake system	Scissor maintenance prop
Emergency descent system	Forklift pockets
Emergency stop button	Load sensing system
On-board diagnostic	AC power to platform
Over tilt protective system	Horn

Accessories & Options

- ▶ Platform work lights
- ▶ Air line to platform
- ▶ Overhead protection bar
- ▶ Low-temperature hydraulic oil



ZOOMLION

Model	ZS0808AC	
	Imperial	Metric
Size		
Work Height (Indoor/Outdoor)	32ft 10in/ 25ft 7in	10.00m/ 7.8m
A - Platform Height-Elevated (Indoor/Outdoor)	26ft 3in/ 19ft 0in	8.00m/ 5.8m
B - Platform Height-Stowed	4ft 2in	1.26m
C - Platform Length	7ft 7in	2.30m
D - Platform Width	2ft 8in	0.81m
Platform Extension	3ft	0.91m
E - Overall Height (Rails Up)	7ft 11in	2.4m
Overall Height (Rails Down)	6ft 3in	1.9m
F - Overall Length	8ft 2in	2.49m
G - Overall Width	2ft 8in	0.81m
H - Wheelbase	6ft 1in	1.85m
I - Ground Clearance (Stowed)	4.5in	0.11m
J - Ground Clearance (Raised)	0.75in	0.02m
Performance		
Platform Capacity	510lb	230kg
Capacity on Deck Extension	250lb	113kg
Max. Number of Workers (Indoor/Outdoor)	2/1	
Drive Speed (Stowed)	2.5mph	4km/h
Drive Speed (Raised)	0.5mph	0.8km/h
Turning Radius (Inside)	4in	0.1m
Turning Radius (Outside)	6ft 11in	2.1m
Lifting Motor	24V/3.3KW	
Drive Motor	24V/2×0.75KW	
Up/Down Time	31s/40s	
Gradeability	25%(14°)	
Max. Working Slope (Lateral/Vertical)	1.5°/3°	
Control	Proportional Control	
Drive	Front Wheels	
Brake	Front Wheels	
Tire	Ø15in Ø381mm x5in x127mm	
Power		
Battery	4×12V/160Ah (TIANNENG)	
Charger	24V/30A	
Weight		
Gross	4610lb	2090kg

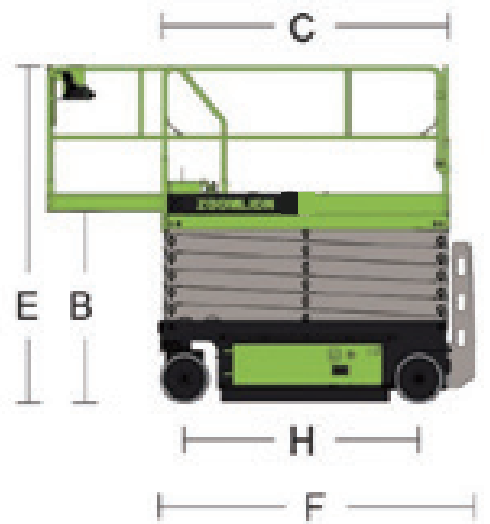
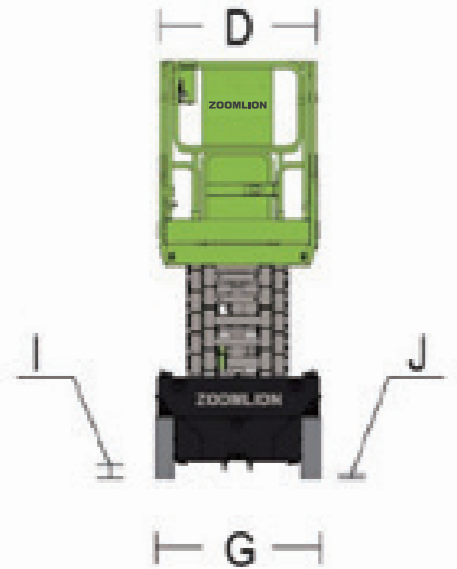
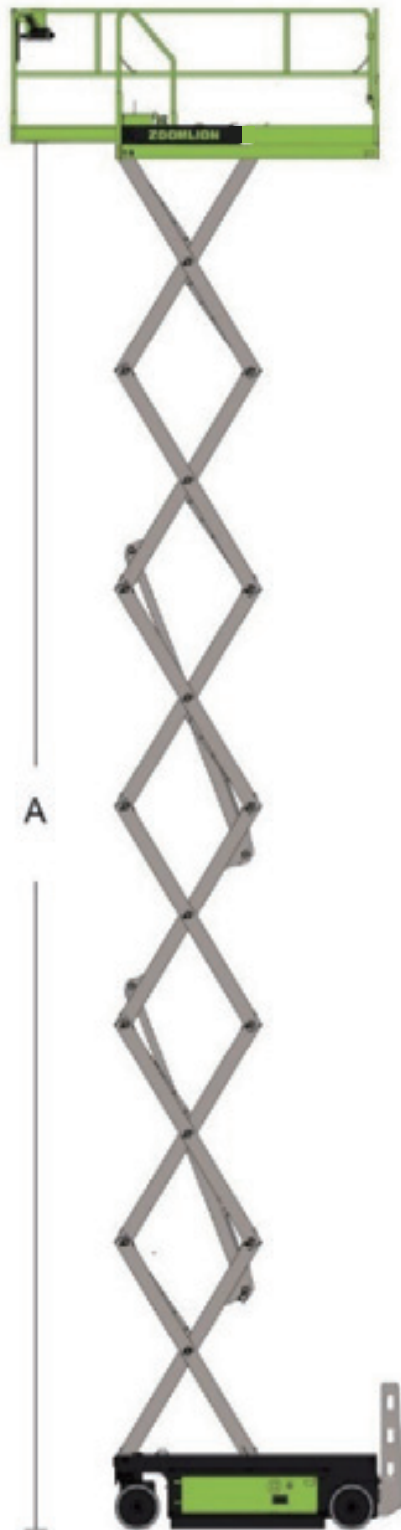

ZOOMLION ACCESS reserves the right to make specification and/or equipment changes without prior notification. Product specifications are updated to January, 2025.

05/06

