



# ELECTRIC SCISSOR LIFT

## AS1413E (AS4650E)

everything, the attitude makes the future

### HIGHLIGHTS

With a platform height of 13.8m, the LGMG AS1413E greatly expands the working height of electric scissor lifts and improves the productivity for the operators in high applications.

- Efficient AC motor drive system provides longer lasting performance and better gradeability.
- 320kg capacity with 0.9m extension deck offers great productivity.
- Battery powered, zero emission and quiet drive mean this machine is environmentally friendly.
- Forklift pockets on both side and rear position for easy handling.
- Swing out component trays for easy access and maintenance.
- Intelligent self-diagnostic system for quick troubleshooting.



**HONEST, RELIABLE & REACTIVE**  
SOLUTIONS FOR WORKING AT HEIGHT



### CONTACT US

- ☎ 0800 865 4455
- ✉ [info@hiresafesolutions.com](mailto:info@hiresafesolutions.com)
- 🌐 [www.hiresafesolutions.com](http://www.hiresafesolutions.com)



# LGMG Electric Motor Drive Scissor Lift

## SPECIFICATIONS

MODELS		AS1413E (AS4650E)	
Measurements	Metric	US	
Working Height Max. (Indoor/Outdoor)	15.8/10m	51.8/32.8ft	
<b>A</b> Platform Height-Raised (Indoor/Outdoor)	13.8/8m	45.3/26.2ft	
<b>B</b> Platform Height-Stowed	1.57m	5.15ft	
<b>C</b> Platform Length	2.64m	8.7ft	
<b>D</b> Platform Width	1.12m	3.67ft	
<b>E</b> Overall Length (with ladder)	2.8m	9.2ft	
<b>F</b> Overall Width	1.3m	4.3ft	
<b>G</b> Overall Height-Rails Up	2.74m	9ft	
Overall Height-Rails Down	1.94m	6.4ft	
<b>H</b> Extension Deck	0.9m	3ft	
<b>I</b> Wheelbase	2.22m	87.4in	
Ground Clearance(Stowed/Raised)	105/20mm	4.1/0.79in	
PRODUCTIVITY			
Platform Occupants Max. (in/out)	2/1	2/1	
Platform Capacity	320kg	705lbs	
Platform Capacity-Extension	120kg	265lbs	
Drive Height		Full Height	
Gradeability-Stowed		25 %	
Turning Radius-Inside		0	
Turning Radius-Outside	2.6m	8.5ft	
Raise/Lower Speed		85/65 s	
Brakes		Front-wheel Brake	
Drive Mode		4×2	
Tires Type		Solid Non-marking	
Tires Size	380×130mm	15×5 in	
POWER			
Power Source		24V DC 300Ah	
HYDRAULIC SYSTEM			
Hydraulic Oil Capacity	25.5L	6.7gal	
WEIGHT			
Machine Weight(CE/ANSI)	3570kg	7870lbs	

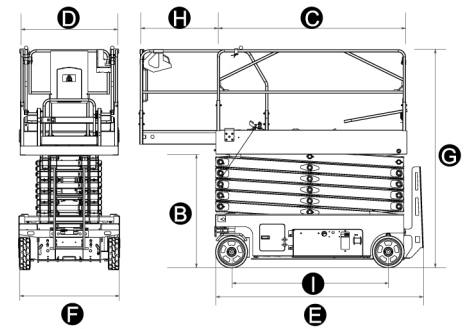

## STANDARD FEATURES

- Proportional control
- Foldable guardrails
- Emergency stop device
- Manual brake release
- Emergency descent
- Swing-out component trays
- Pothole guards
- Self-lock entry gates
- Tilt alarm with lift cut-out
- Overload sensing system
- Descent alarm with flashing beacons
- Horn/Hour meter
- All motions alarm
- Full-height drive\*
- Intelligent diagnostic system

## OPTIONAL

- AC power to platform
- Platform anti-collision device
- Air tube to platform
- Maintenance-free battery
- Lithium battery
- GPS

(Note:\* Max. drivable height for AS1413E is 8m outdoor use)

