

AB14EJ(AB460EJ)/AB16EJ(AB520EJ)

Compliant with CE/ANSI/CSA standards

Model	AB14EJ(AB460EJ)		AB16EJ(AB520EJ)	
	Metric	US	Metric	US
Dimensions				
Max Platform Height	14m	45'11"	15.7m	51'6"
Max Working Height	16m	52'6"	17.7m	58'1"
Max Horizontal Extension	7.6m	24'11"	9.3m	30'6"
Max Up and Over Clearance	7.8m	25'7"	7.8m	25'7"
A Length-Stowed	6m	19'8"	6.8m	22'4"
B Width-Stowed	1.73m	5'8"	1.9m	6'3"
C Height-Stowed	2m	6'7"	2m	6'7"
D Wheelbase	1.9m	6'3"	1.9m	6'3"
Ground Clearance	0.22m	8.7"	0.22m	8.7"
Platform Dimensions(LxWxH)	1.45x0.85x1.1m	57x33.5x43"	1.45x0.85x1.1m	57x33.5x43"
Performance				
Platform Capacity(Unrestricted/2 Persons)	230kg	507lbs	230kg	507lbs
Turntable Rotation	355°		355°	
Platform Rotation	160°		160°	
Drive Speed-Stowed	5.2km/h	3.2mph	5.2km/h	3.2mph
Drive Speed-Raised	0.8km/h	0.5mph	0.8km/h	0.5mph
Gradeability	30%		30%	
Turning Radius-Inside	1.15m	3'9"	0.7m	2'3.5"
Turning Radius-Outside	3.51m	11'6"	3.31m	10'10"
Turntable Tailswing	0	0	50mm	2"
Tilt Rating	5°		5°	
DrivexSteer	2WDx2WS		2WDx2WS	
Tyres Spec/Type	240/55D17.5 Foam-filled tyres			
Power				
Batteries	8x6V,420 Ah		8x6V,420 Ah	
Auxiliary Power Unit	12V DC		12V DC	
Hydraulic Tank Capacity	40L	8.8gal	40L	8.8gal
Weight				
Weight	7,100kg	15,653lbs	7,300kg	16,094lbs
Standards Compliance	CE/ANSI/CSA			

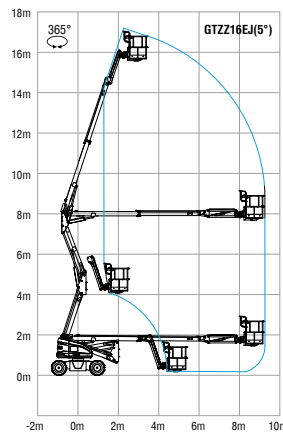
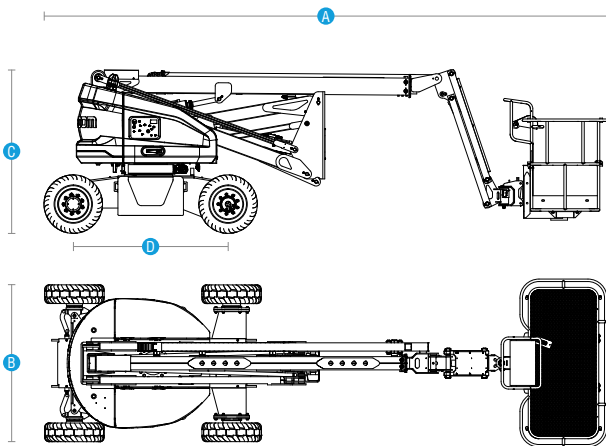

Electric Articulated Boom Lifts

AB14EJ(AB460EJ)/AB16EJ(AB520EJ)

Compliant with CE/ANSI/CSA standards

Product Highlights

Suitable for narrow spaces

- Narrow body of 1.9m(6'3"), 50mm(2") tail sweep is almost zero

Green

- Fully battery-powered, silent, zero emissions, long battery life, especially suitable for indoor work

Precision performance

- 3 joysticks with variable proportional control, boom swing, boom extension, turntable rotation and walking speed, smooth start and stop motion, accuracy in reaching the operation target

Smart maintenance

- Smart screen display, fault and status information display for easy viewing of machine status and fault diagnosis, parameters and settings

Industry-leading adaptability

- Large tilt angle up to 5°

Standard features		
■ Platform hydraulic leveling	■ Overload sensing system	■ 355° Turntable rotation
■ Platform 160° hydraulic rotation	■ Main boom gravitational lowering	■ Emergency brake release
■ Drive enable system	■ Display screen	■ Foam-filled tyres
■ Full proportional handle variant control	■ Fault diagnosis system	■ IOT-based operation monitoring
■ Horn and buzzer alarms	■ Emergency stop system	■ Lead-acid battery
■ Rotating warning lamp	■ Emergency lowering system	■ Rexroth pump system
■ Tilt protection	■ Tilt angle up to 5°	
Optional features		
■ Headlight	■ AC cable to platform	■ Non-marking tyres
■ Optional 1.83m(6') work platform	■ Overhead anti-collision device	

