

The data in this brochure are informative and subject to change without notice

REV08.A

# 5.25SH

# RTH



Maximum lifting height: 25.00 m  
Maximum reach: 21.20 m  
Electronically controlled hydrostatic transmission  
Automatic levelling device  
Scissors stabilizers



**HONEST, RELIABLE & REACTIVE**  
SOLUTIONS FOR WORKING AT HEIGHT

**CONTACT US**

0800 865 4455  
info@hiresafesolutions.com  
www.hiresafesolutions.com



## RTH 5.25 SH

MACHINE MODEL	Rotary telescopic handler	RTH 5.25 SH	
	Maximum lifting capacity	4,999 kg (center of gravity 500 mm)	
	Maximum lifting height	25,00 m	
	Rotation	360° (continuous)	
ENGINE	Type	Deutz TCD 3.6 L4 - stage IV	Deutz TCD 3.6 L4 EDG - stage III A compliant
	Rated Power	100 kW - 134 hp @ 2,200 rpm	100 kW - 134 hp a 2,200 rpm
	Maximum torque	500 Nm @ 1,600 rpm	500 Nm @ 1,600 rpm
	Displacement	3,6 l	3,6 l
	Cylinders	4 in line	4 in line
	Fuel	Turbocharged direct injection diesel	Turbocharged direct injection diesel
	Cooling System	Water - intercooler	Water - intercooler
TRANSMISSION	Type	Hydrostatic	
	Model	Bosch - Rexroth	
	Maximum pressure	500 bar	
	Displacement	Electronically controlled variable displacement pump Variable displacement motor	
	Gearbox	Dropbox, 2 speeds forward-reverse	
AXLES AND BRAKES	Type	Axles with planetary gearboxes	
	Rear axle	Steering	
	Front axle	Oscillating and steering with levelling +/-10°	
	Service brake	Hydraulically operated wet multi-disk brakes on each axle	
	Parking brake	Hydraulic with negative action	
	Tyre sizes	445/65 R 22,5	
PERFORMANCE	Max. travel speed	40 km/h	
	Drawbar pull	66 kN	
	Gradeability	41%	
	Turning circle (at forks)	6,390 mm	
WEIGHTS	Total unladen	18,000 kg	
	Front axle unladen (boom retracted and lowered)	8,100 kg	
	Rear axle unladen (boom retracted and lowered)	9,900 kg	
TANK AND SYSTEM CAPACITIES	Diesel fuel tank	180 l	180 l
	AdBlue	10 l	N/A
	Hydraulic fluid	190 l	190 l
	Engine oil	8 l	8 l
	Coolant	23 l	23 l
HYDRAULIC CIRCUIT FOR MOVEMENTS	Max. working pressure	350 bar	
	Circuit type	Load sensing	
	Service pump	Bosch Rexroth - Variable displacement	
	Distributor for boom and turret movements	Danfoss - SIL 2 electro-proportional valve	
	Distributor for stabilisers	Bosch Rexroth - Electro-hydraulic actuators	
	Movements control	2 no. two-axis Danfoss joysticks with deadman safety device Managed via CAN bus	
STANDARDS MET	EN 13849: concerning the safety of all machine controls EN 13000: concerning standards for hydraulic cranes EN 280: concerning standards for mobile elevating work platforms FOPS/ROPS EU 2016/1628: concerning engine emissions standards EN 1459-2: concerning standards for slewing variable-reach trucks		

The data in this brochure are informative and subject to change without notice

REV08.A

### MAIN SECTORS

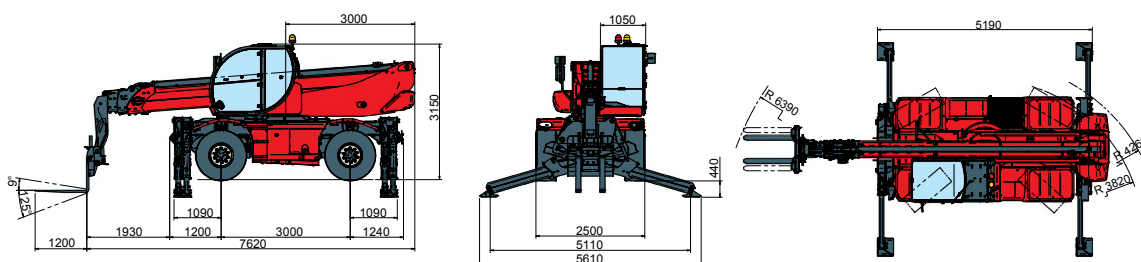
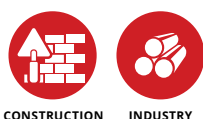

**HONEST, RELIABLE & REACTIVE**  
SOLUTIONS FOR WORKING AT HEIGHT

### CONTACT US

0800 865 4455  
 info@hiresafesolutions.com  
 www.hiresafesolutions.com



**360° LOAD CHART  
ON FULLY EXTENDED STABILISERS**

**ON STABILISERS**

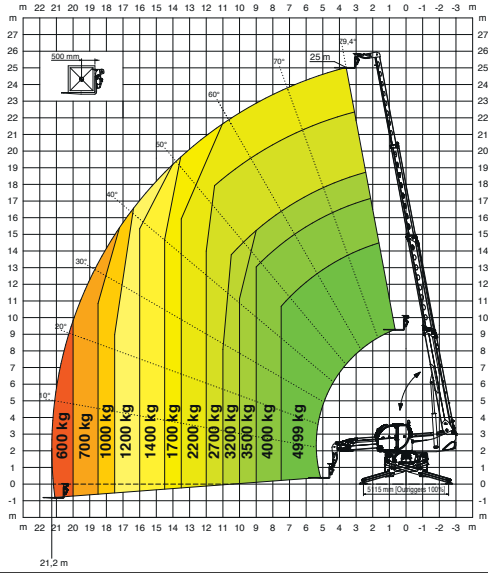

**FRONT LOAD CHART ON TYRES**

**ON TYRES**

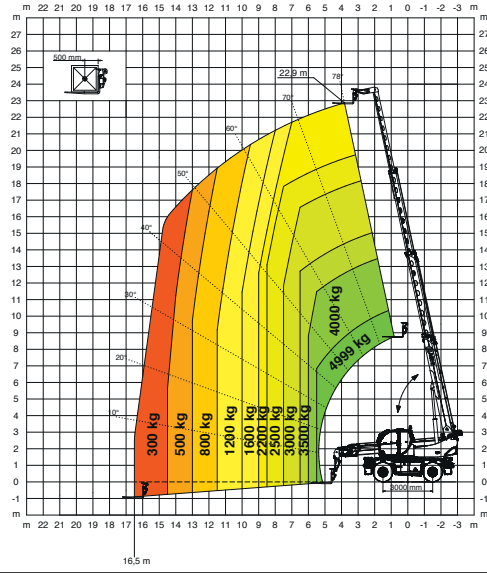

**WINCH 3,500 kg**

**W 3,5**

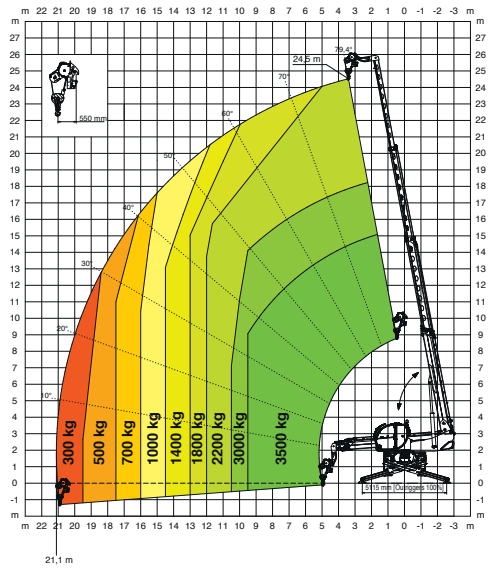

**WINCH 5,000 kg**

**W 5**

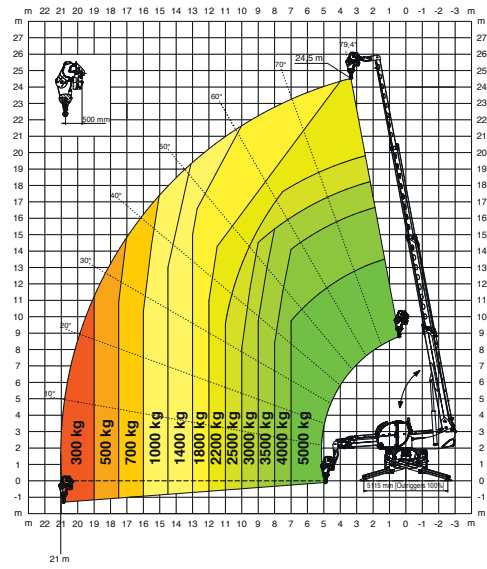

**JIB WITH WINCH 1,500 kg**

**JW 1500**

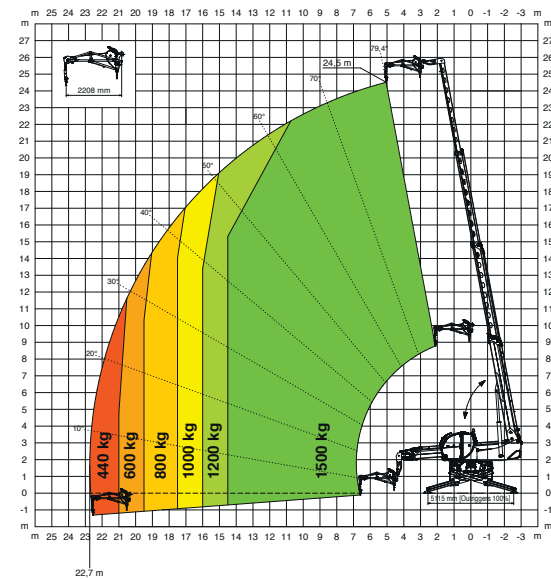

**JIB WITH WINCH 2,000 kg**

**JW 2000**

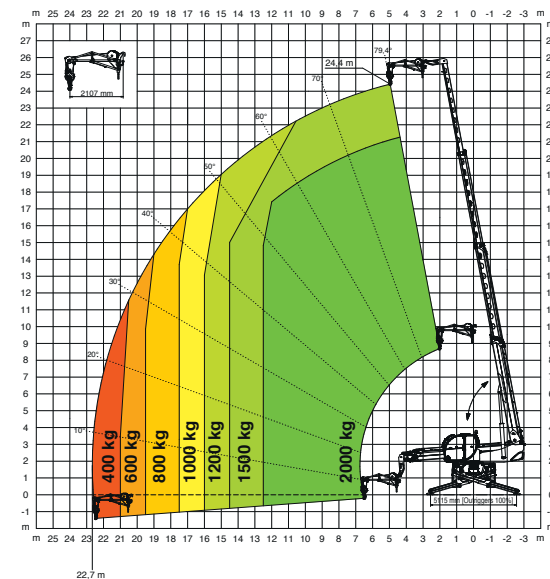

JIB WITH WINCH **3,000 kg**

JW 3000

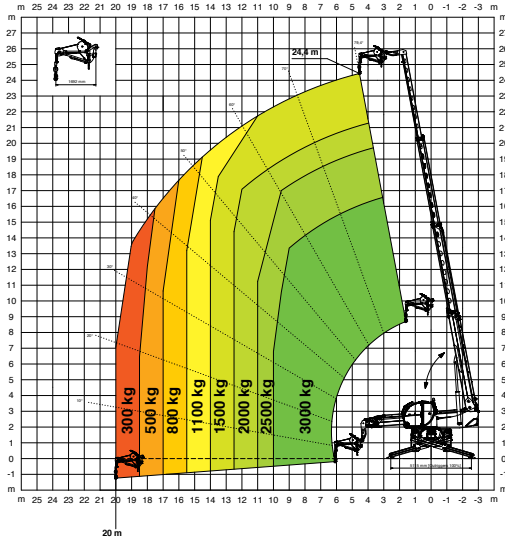

JIB **2,000 kg**

J 2000

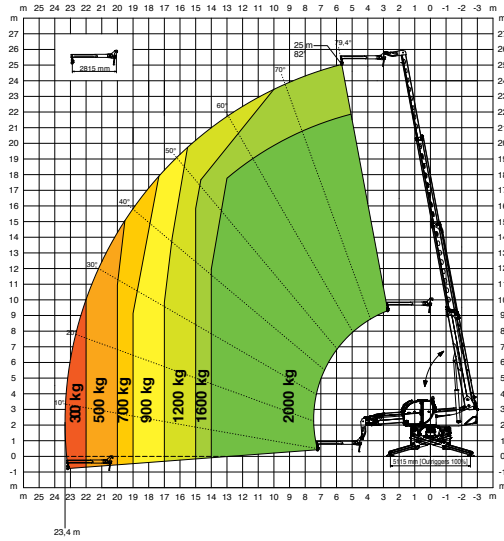

HOOK **5,000 kg**

H 5

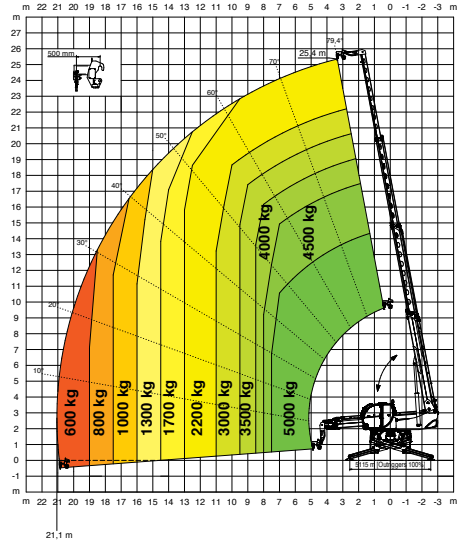

ROTATING EXTENDABLE BASKET **500 kg**

REP 2-4,5

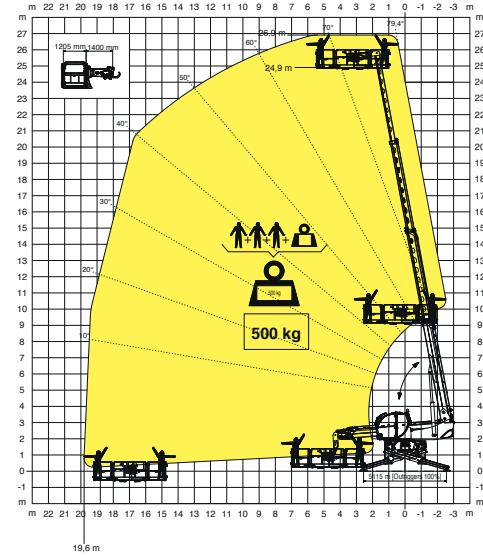

ROTATING EXTENDABLE BASKET **1,000 kg**

REP 10.2-4,7

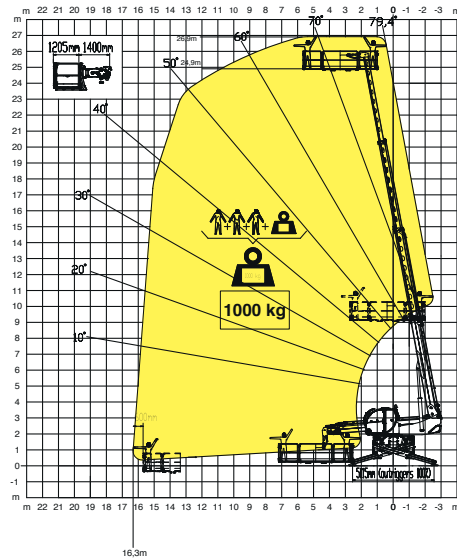

BASKET 4.7 m **800 kg**  
WITH WINCH **300 kg**

REP 8,2-4,7 W0,3

