

STATIC DIMENSIONS

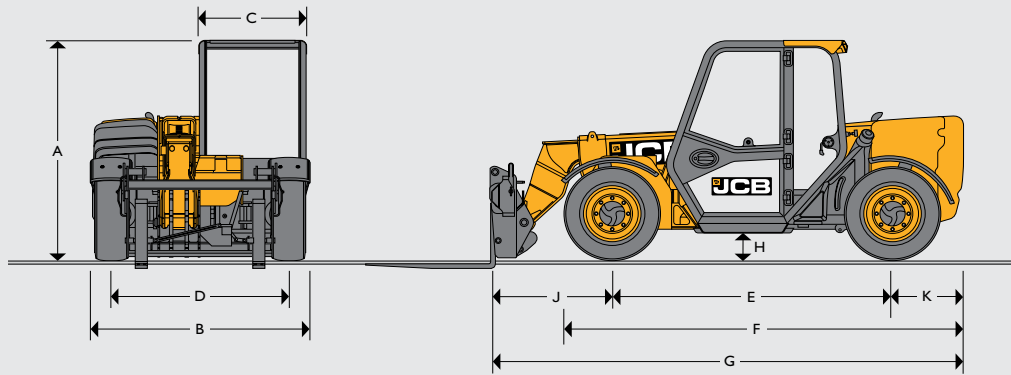

A	Overall height*	m	1.89
B	Overall width (over tyres)*	m	1.84
C	Inside width of cab	m	0.88
D	Front track	m	1.53
E	Wheelbase	m	2.39
F	Overall Length to front tyres	m	3.38
G	Overall length to front carriage	m	4
H	Ground clearance	m	0.23
J	Front wheel centre to carriage	m	1.02
K	Rear wheel centre to rear face	m	0.6
	Carriage roll back angle	degrees	11
	Carriage dump angle	degrees	114
	Weight	kg	5490
	Tyres	industrial	12x16.5

*Dependant upon tyre specified.

LIFT PERFORMANCE

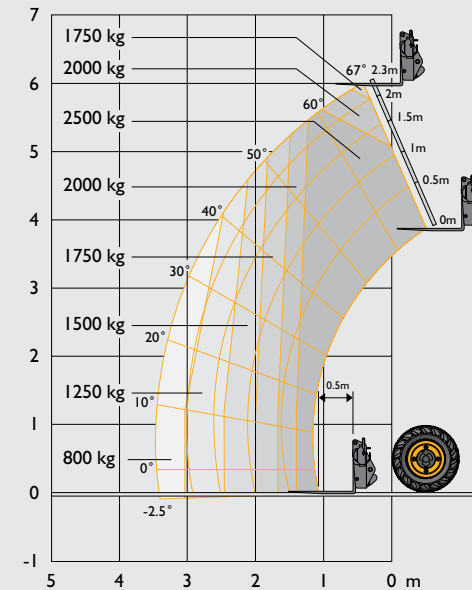

Maximum lift capacity	kg	2500
Lift capacity to full height	kg	1750
Lift capacity at full reach	kg	800
Lift height	m	6
Reach at maximum lift height	m	-0.15
Maximum forward reach (to front of carriage)	m	3.06
Reach with 1.2 tonne load	m	2.64

Complies with stability test EN 1459 Annex B.



HONEST, RELIABLE & REACTIVE
SOLUTIONS FOR WORKING AT HEIGHT



CONTACT US

0800 865 4455

info@hiresafesolutions.com

www.hiresafesolutions.com



ENGINE

Latest Tier 4 Final technology and advanced design provides low fuel consumption, reduced noise, high torque and power output, total reliability and minimal maintenance. Two-stage, dry type air filter with primary and safety elements. Territory dependent.

Manufacturer	JCB DIESEL BY KOHLER	
Displacement	ltr	2.5
No. of cylinders		4
Bore size	mm	88
Stroke	mm	102
Aspiration	Turbocharged cooled	
Power rating		
Power @ 2200rpm	kW (hp)	55 (74)
Torque rating		
Torque @ 1500rpm	Nm	300

HYDRAULICS

Two stage gear pump, fitted with suction strainer and filter. One boom end auxiliary hydraulic service fitted as standard.

Operating system pressure	bar	260
Flow at system pressure @ 2200rpm	ltr/min	80
Hydraulic cycle times		Seconds
Boom raise		7.6
Boom lower		5.3
Boom extend		7.5
Retract		3.7
Bucket dump		1.9
Bucket crowd		2.9

TRANSMISSION

Closed loop variable displacement pump with a continuously variable hydrostatic drive. Comprising of a hydraulic motor and control unit. Permanent 4 wheel drive. Travel speed: 25kph (15mph), 20kph (12mph) (TUV).

		Forward	Reverse
Low Range	kph	8	8
Hi-Range	kph	25	25

ELECTRICS

System voltage	Volt	12
Alternator output	Amp hour	80
Battery capacity	Amp hour	120

Full road lighting. Reversing light. Direction indicators. Hazard warning. Reverse alarm.

AXLES

Front and rear drive axles: epicyclic hub reduction drive/steer axles with torque proportioning differentials.

BRAKES

Service brakes: Hydraulically operated self-adjusting, oil-immersed in-board multi-disc type mounted on front axle.

Parking brake: SAHR Handbrake self adjusting, oil immersed in-board multi disc type mounted on front axle operated by in-cab switch.

SERVICE FILL CAPACITIES

Hydraulic system	litres	65
Fuel tank	litres	75

BOOM AND CARRIAGE

Boom is manufactured from high tensile steel. Low maintenance, hard wearing pads. JCB Q-Fit, JCB compact toolcarrier, Skid-Steer.

STEERING

Hydrostatic power steering with power track rods on both axles.

Three steer mode options: Front wheel steer, all wheel steer, crab steer, operated from in the cab by a selection lever.

Option: In cab selector switch with Auto Align.

CAB

Quiet, safe and comfortable cab conforms to ROPS ISO 3471 and FOPS ISO 3449. Tinted glass all round, with laminated roof screen. Roof bars, front screen and roof screen wipers and heater/screen demister. Rear opening window with wash/wipe. Audio-visual warning system for coolant temperature, engine oil pressure, air-cleaner, battery charge, transmission oil temperature and pressure, water in fuel, hourmeter, road speed indicator, fuel gauge, engine temperature, clock and inclinometer. Adjustable suspension seat, tilt steer column, park brake, floor mounted throttle and brake pedals.

Hydraulic controls: Single lever servo joystick, incorporating forward/neutral/reverse, with progressive extend/retract and auxiliary incorporating constant flow facility.

Load Moment Indicator: Automatic eye level audio-visual load moment indicator warning system receiving a signal from a load sensor on the rear axle. This system continuously monitors the machine's forward stability and leaves the operator in control at all times.

OPTIONS

Options: Canopy front and rear working lights, rotating flashing beacon, fire extinguisher, front screen guard, air conditioning, industrial tyres, 2 boom end auxiliary services, sunblind, radio kit, carriage hydraulic locking, limited slip differential in front axle, air suspension seat, 2-speed and intermittent front wash/wipers.

Attachments: Contact your local dealer for details of the comprehensive range.

*Adaptive Load Control for EU territories conforms to EN15000.



HONEST, RELIABLE & REACTIVE
SOLUTIONS FOR WORKING AT HEIGHT



CONTACT US

0800 865 4455

info@hiresafesolutions.com

www.hiresafesolutions.com

