

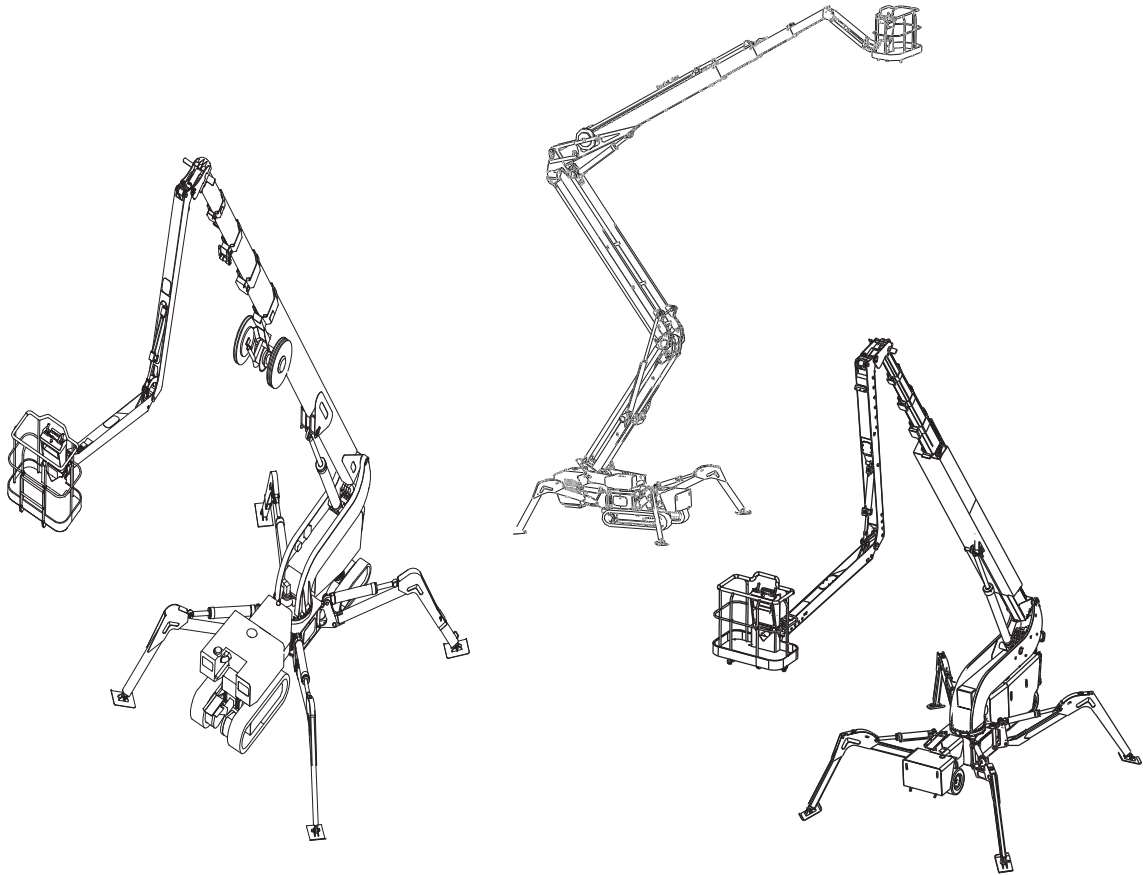

OPERATORS MANUAL



FALCON

MEWP in accordance with ANSI/SAIA A92.20-2018

original Language

Dansk

English

Deutsch

WARNING

Do not use the platform without reading and following the instructions carefully. Failure to comply with the correct operating procedures and safety instruction, can cause personnel injury or death.

Table of Contents

Information	2
Summary of WARNINGS	6
1.0 Introduction	12
1.1.01 Handling by crane	13
1.1.02 Transportation in containers	13
1.1.03 Remove ropes	13
1.1.04 Turn main switch on	13
1.1.05 Remove wooden blocks	13
1.1.06 Important	13
2.0 Supplements	14
Description of the control panels	15
Supplement C	16
Supplement D	17
Supplement E	18
3.0 Electrical equipment	19
3.1.01 Engaging the electrical system	20
3.1.02 Choice of control	20
3.1.03 Stability system	20
3.1.04 Controls on the platform	21
3.1.05 Charge indicator	21
3.1.06 Battery capacity Indicator	21
3.1.07 Basket rotator (Option)	22
3.1.08 Acoustic signals	22
4.0 Hydraulic equipment	23
4.1 Hydraulic equipment	24
4.1.01 Power transmission	24
4.1.02 Activation of main boom	24
4.1.03 Activating outriggers	24
4.1.04 Controls of the platform	24
4.1.05 Basket locked	24
4.1.06 Basket levelling	24
4.1.07 Emergency lowering	24
5.0 Operators Instructions	25
5.1.03 Change the axle width	27
5.2 Setting up the outriggers	28
5.2.01 Setting up the outriggers	31
5.2.03 Setting up the outriggers	34
5.2.04 Stowing the outriggers	35
5.3 Before using the platform	35
5.3.01 Mounting the basket	35
5.3.02 Power supply	35
5.3.03 Diesel engine	35
5.4 Operating the platform	37
5.4.02 Basket Control Panel	39
5.4.03 Chassis Control Panel	40
5.4.04 Description of the remote control	42

5.4.05	Description of Display	43
5.4.06	Startup	47
5.4.07	IDRC	48
5.4.08	Lift Function	49
5.4.09	Driving	49
5.4.10	Setting up the outriggers	50
5.4.11	Alternate functions from remote control	
6.0	Emergency Lowering General	53
6.1	Electrical pump	55
6.1.01	Basket levelling	56
6.1.02	Emergency lowering Telescopes	56
6.1.03	Emergency lowering Slewing	57
6.1.04	Emergency lowering Link arm	58
6.1.05	Emergency lowering Main boom	59
6.2	Emergency lowering	60
6.2.01	Basket levelling	61
6.2.02	Emergency lowering	62
6.2.03	Emergency lowering Slewing	62
6.2.04	Emergency lowering Link arm	63
6.2.05	Emergency lowering Main boom	63
7.0	After using the platform	64
8.0	Transporting the platform	66
9.0	Safety Instructions	70
10.0	Inspection and maintenance	72
10.1	Daily inspection	72
10.2	Weekly inspection	72
10.3	Monthly inspection	72
10.4	Yearly inspection	74
10.5	Inspection and maintenance	75
10.6	Spare parts modification	77
10.7	Tightening of the crawler belts	77
10.7.1	Tightening of the crawler belts	77
10.8	Tightening of the crawler belts	78
10.9	Lubrication diagram	79
Appendix		82
Appendix A:	Sliding tracks	83
Appendix B:	Key switch at the turret	83
Appendix C:	Outriggers with hinged joints. (Option).	85
Appendix D:	Reduced working height	86
Appendix E:	Twin wheels	86

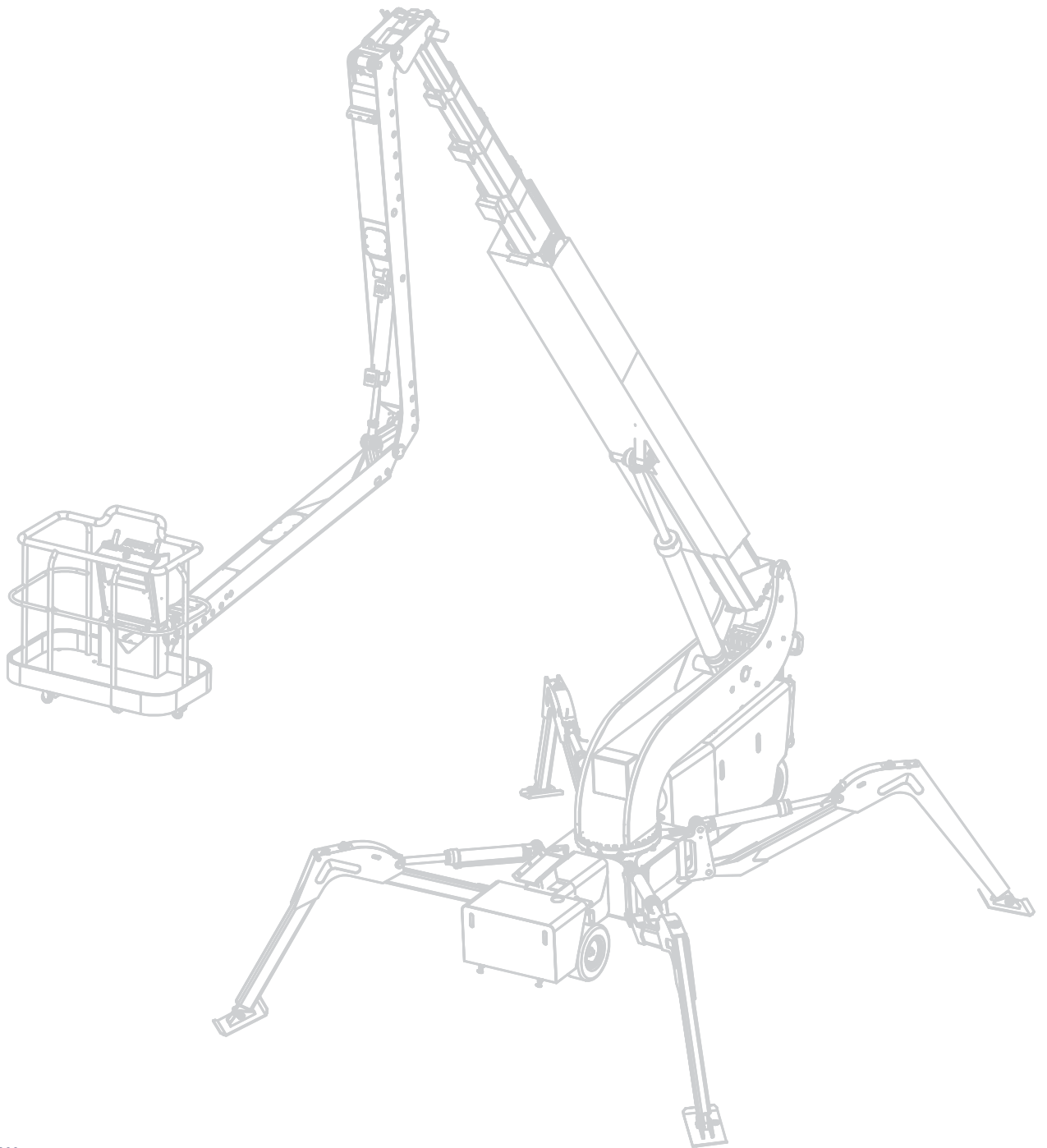

Summary of WARNINGS

In this chapter you will find:

- Summary of essential **WARNINGS**



Summary of WARNINGS

At page:

- 13 WARNING**
Do not attempt to open any boxes containing electrical components, when mains are connected to the machine. Contact with the main supply can cause injury or death. Before opening the boxes with electrical components, mains must be disconnected from the machine. Repair work with 24V DC power connected may only be performed by authorized personnel.
- 20 WARNING**
Do not attempt to use the platform if red indicator lights at the outriggers are not ON, when the outriggers are in the stowed position or without a load. If the red “STABILITY” indicator lights are out when the outriggers are lifted from the ground, the safety system has a malfunction. Failure in the safety system can cause injury or death. Call an authorised service centre immediately.
- 24 WARNING**
If a chain is too slack, the platform should be brought to the ground immediately. Operating the platform with a broken chain, can cause injury or death. Call an authorised service centre immediately.
- 24 WARNING**
Follow the safety instructions carefully.
- 24 WARNING**
When operating the platform from the ground by engaging the hydraulic valves directly the safety system is not functioning and the operator must pay highly attention to every move and follow the emergency lowering procedure. “Telescopes In” is the only function to be used until the telescopes are fully retracted. Failure to do so can cause injury or death. Call an authorised service centre immediately.
- 28 WARNING**
When the rear axles are not locked with the locking pin, the rear axle can fall out and the platform may tip over, causing serious injury or death.
- 28 WARNING**
When driving the platform with the axles in the stowed position, keep the platform on hard, flat ground and in low speed. If the platform is driven on a slope it can tip over and cause injury or death.
- 28 IMPORTANT**
Use the widest axle width possible at all times.
- 28 WARNING**
Do not attempt to drive the lift if the axles are not completely out or completely in. The platform may tip over, causing serious injury or death.
- 29 WARNING**
Do not attempt to use the platform if the red lights on the outriggers or the “STABILITY” indicator lights are not ON when the outriggers are in stowed position or the outriggers are without a load. If the red “STABILITY” indicator lights are out when the outriggers are lifted from the ground the safety system has a malfunction. Failure in the safety system can cause injury or death. Call an authorised service centre immediately.
- 29 WARNING**
Outrigger plates must always be mounted at the outrigger and secured before attempting to lift the platform off the ground.
- 29 WARNING**
Setting up the platform on soft ground can make the platform unstable and cause serious injury or death. Only set up the platform on hard flat ground. Load applied to the ground is given in the technical data. Setting up the outriggers – General
- 30 CAUTION**
When lowering the outriggers make sure that there is no interference with the pumps and diesel engine. Do not lower the outriggers when they are locked in the stowed position. This is not a working position and can cause interference with chassis resulting in structural damage.

- 30 WARNING**
When lowering the outriggers, do not lift the platform more than 0,6 m. from the ground. The platform does not stop automatically. Failing to do so can cause injury or death.
- 30 WARNING**
If the outrigger base of the outrigger is not locked to the chassis frame the outriggers can turn, resulting in instability which can cause injury or death. Locking bolt for securing the outrigger base to the chassis frame must always be in position before attempting to lift the platform off the ground.
- 31 WARNING**
Only adjust Track width when the tracks are free of ground.
- 32 WARNING**
When positioning the outriggers on the ground it is important to ensure that all limbs are kept clear of the outriggers, outrigger plates and any other moving parts. Failing to do so can cause injury or death.
- 32 WARNING**
Setting up the platform out of horizontal level to the ground can give instability and cause injury or death. The platform must be set up with chassis in horizontal level.
- 34 WARNING**
Do not set up the platform, when the outriggers are in **Red** position (Suppl. C, Pic II) (Stowed position). This is **ONLY** transport position. Failing to do so can be a cause for injury or death.
- 35 WARNING**
When mounting the basket make sure that the basket is locked properly. A basket not locked properly can fall of and cause injury or death.
- 35 WARNING**
When the platform is used for welding work the platform has to be unplugged and the outriggers have to be placed on rubber mats.
- 37 WARNING**
The basket is not insulated for work with or near high voltage installation. Work in assured clear distance from elektrisk power lines. Failing to do so can result in electrocution causing injury or death.
- 37 WARNING**
Do not attempt to climb outside the basket when it is lifted from the ground. Always make sure you use a safety belt as required by your employer or the appropriate fall protection. Falling from the platform can cause injury or death.
- 37 WARNING**
Do not attempt to climb on top of the basket or to use a ladder or likewise from the basket.
- 37 WARNING**
Overloading the platform can cause serious injury or death. Do not overload the basket, or attempt to use the basket or the platform as a crane.
- 37 WARNING**
Before entering the basket it must be controlled that the basket is properly locked to the basket suspension. Do not attempt to use the platform without the use of a safety belt. The safety belt must be properly locked in the fixing point.
- 38 WARNING**
Always pay attention to the position of the outriggers, turret and Link-arm system while slewing. There can be danger of collision between outrigger(s) and Link-arm system and/or between the turret and outrigger(s). Failing to do so can cause structural damage to the platform.
- 38 WARNING**
When folding out the Link-arm system, make sure there is no collision between the Link-arm system and the cover(s). Raise the main boom and extend telescopes before folding out the Link-arm system. Failing to do so can cause structural damage to the platform
- 53 WARNING**
When operating the platform from the

ground, by engaging the emergency valves directly, the safety system of the platform is out of function. When operating the platform directly from the emergency valves “Telescope in” is the only function to be used. Failing to do so, can cause personnel injury or death. Call authorised maintenance immediately.

56 WARNING

When activating the Emergency valves at the turret, the safety system of the platform is out of function. It is necessary to operate the platform very carefully and pay highly attention to every move. Failing to do so can cause injury or death.

65 CAUTION

Do not let the basket hit the ground. This can cause structural damage to the platform.

65 CAUTION

The **red** stability lights at the outriggers **MUST** come on when the outriggers are raised from the ground. Failure in the safety system can cause injury or death. Call authorised service centre immediately.

65 CAUTION

When the platform is transported, the outriggers must be raised minimum 5 cm. from the ground.

67 CAUTION

It is important that all 4 outriggers have the same load when loading, unloading and during operation. Notice the **red** lights on the outriggers. Always keep the platform horizontal while loading and unloading. Activate the outriggers 2 by 2, front and rear.

67 WARNING

Do not set up the platform when the outriggers are in **Red** position (Stowed). This is ONLY a transport position.

76 WARNING

If the **red** lights do not light up or the scale does not show allowed weight according to table column A, call an authorized service centre immediately. Failure in the safety system can result in injury or death.

76 WARNING

If the scale shows more than maximum allowed weight according to table column B, call an authorized service centre immediately. Failure in the safety system can result in injury or death.

83 CAUTION

Mounting of the sliding tracks with the outriggers in stowed position (**Red**) can cause structural damage to the platform.

83 WARNING

Never use this function with wheels in narrow position, always make sure that rear wheels are set in maximum wide position before engaging this feature. Never raise the boom above 2,4 m. in this mode, measured from floor to end of main boom.

Always use maximum care when driving the unit in this position and only use it when it is absolutely necessary. As soon as surroundings permit driving the lift in normal position (secured in the cradle) lower the main boom as per below instructions.

Always take basket off before switching this mode.

Never work, place or put anybody or anything in the basket in this mode, this is strictly a transportation mode to pass obstacles on the floor that not otherwise can be passed.

83 WARNING

Driving the platform with the main boom in raised position is only allowed on horizontal surface. Drive slowly and pay attention to the balance of the platform. Driving the platform on non-horizontal surfaces, can cause the platform to turn over and result in personnel and/or material injury or death.

84 WARNING

Do **NOT** use any platform functions, when the key-switch is turned to the right.

Beware of basket turning!

When the main boom is lifted, the basket can be turned 90°. When lowering the main boom and the link arm is retracted the basket will collide with the main boom. Extract the link arm to avoid collision with any part when the basket is mounted.

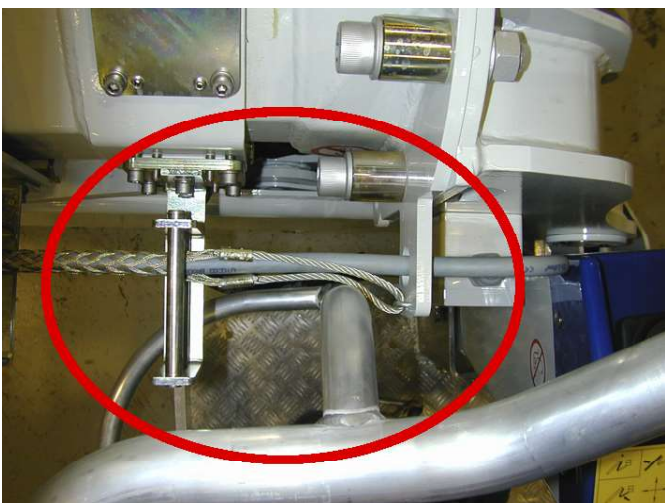
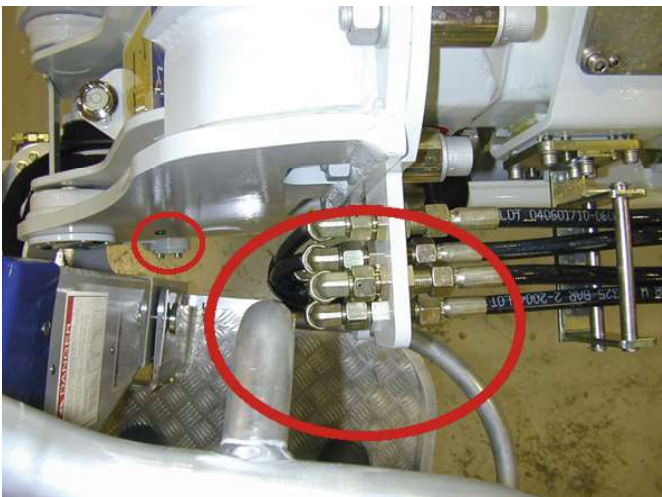
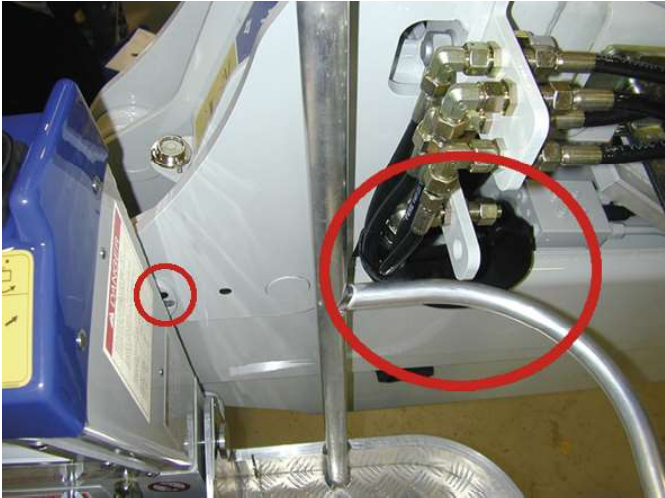

Transporting the Falcon

Strapping the Falcon for Transportation

Recommended strapping illustrated below:

1. Fasten straps across turret
2. Fasten straps through the eyes on each outrigger knee joint.
3. Fasten straps through the eyes on each side of boom at the basket end.

In order to minimize wear and tear on the lift due to strapping:

Place blocks under the sandwich prior to strapping down the lift.

Use straps only and not chains.

Insert cloth or other padding between the lift and straps in the areas where the straps come in contact with the lift.

Failure to follow these instructions may result in severe damages to the lift.

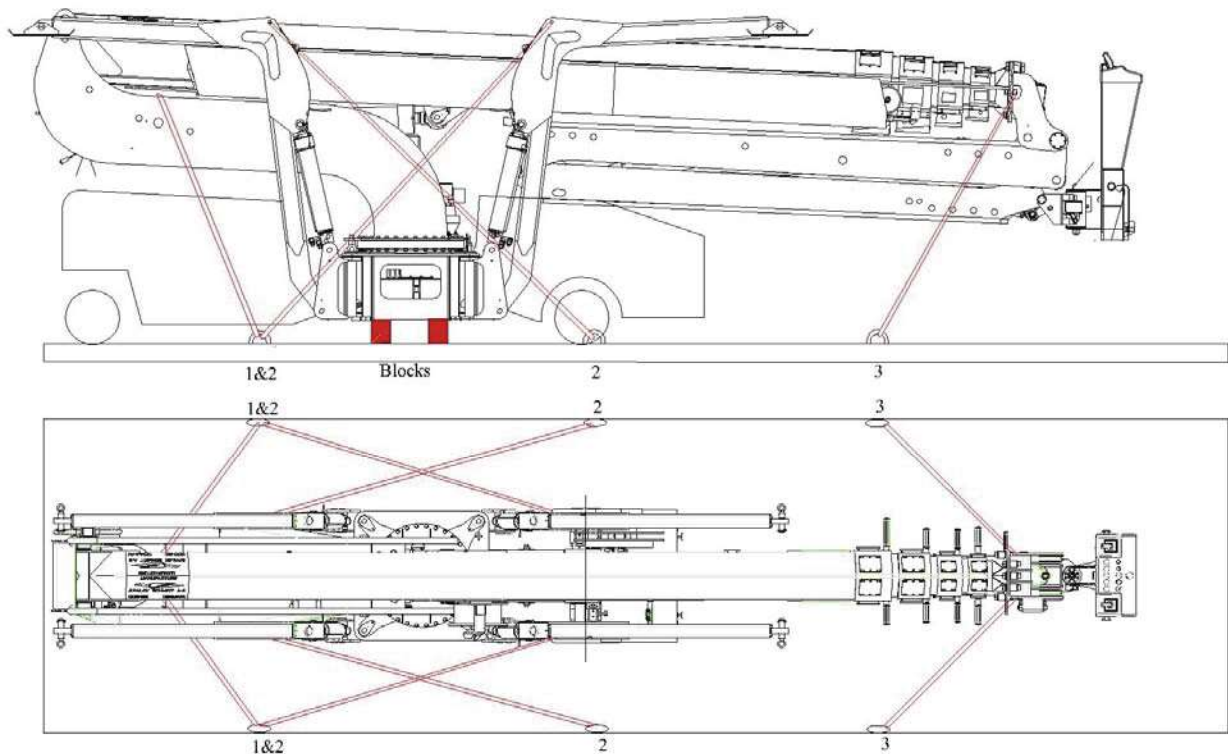

Preparing the Basket for transportation

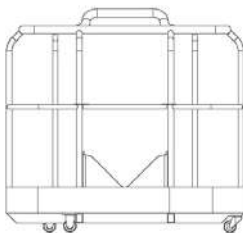

When transporting the lift as shown above, the basket should be removed from the lift and strapped separately. To prevent damage to the casters, the basket should be raised off the ground onto a wooden block.

1.0 Introduction

In this chapter you will find:

- **How to handle by crane**
- **How to remove the ropes**
- **How to remove wooden blocks**

1.1 Introduction
1.1.04 Turn main switch on
1.1.01 Handling by crane

If the platform is received on truck and has to be handled with crane the platform can be lifted off the truck by a crane. The outriggers shall be placed in narrow position (**orange**)

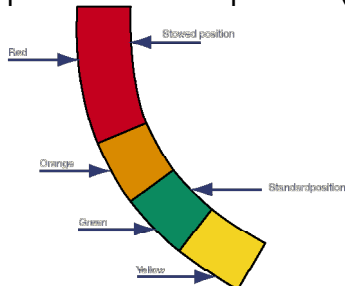

(not transport position) and the crane must be attached to the fixing points at the outriggers. Length of lifting chains on crane must be adjusted to give balance of the platform as centre of gravity is not located in the middle of the outriggers attach points.

See fig 1



Fig. 1

1.1.02 Transportation in containers

The following precautions must be observed/ noticed when receiving these machines, in the order described below. Please note that the description below is only in a short form, and that the appropriate sections of this document have to be read and followed thoroughly.

1.1.03 Remove ropes

The platform is strapped to the container with ropes etc. These ropes can be used for later strapping of the machine on a truck flatbed, etc.

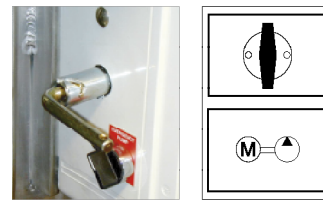

Turn on the main switch situated next to the turn switch for the emergency pump at the right side of the platform. Turn the key switch to „control from chassis“

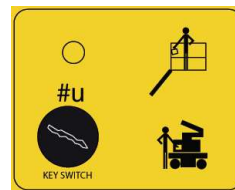

Check battery capacity indicator (round instrument) at the Chassis control panel (suppl. A) at the front of the platform.

WARNING

Do not attempt to open any boxes containing electrical components, when mains are connected to the machine. Contact with the main supply can cause injury or death. Before opening the boxes with electrical components, mains must be disconnected from the machine. Repair work with 24V DC power connected may only be performed by authorized personnel.

1.1.05 Remove wooden blocks

The wooden blocks supporting the chassis shall be removed by the means of ordinary hand tools.

Please make sure that the upper control box does not interfere with the container roof.

1.1.06 Important

- As soon as possible, the platform must be connected to mains outlet and charged.
- Avoid leaving the platform for several days without charging.
- Use a ramp while driving the platform of the container.
- As soon as the platform has left the container set the axle width to the widest position possible.

2.0 Supplements



Description of the Control Panels

Chassis and Basket

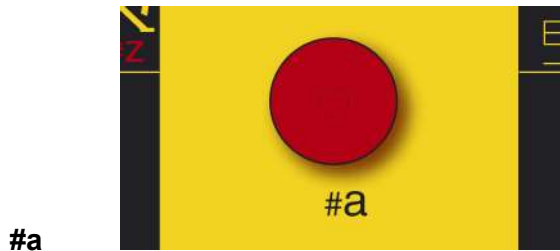

#a

EMERGENCY STOP BUTTON
Pushbutton.

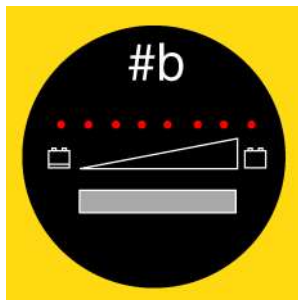

#b

BATTERY INDICATOR
It is recommended not to work with the with battery capacity below 20%

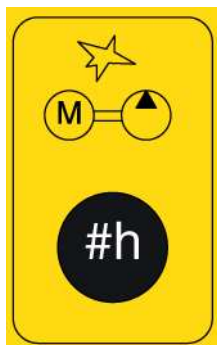

#h

PUSHBUTTON
STARTS PUMP FOR OUTRIGGERS

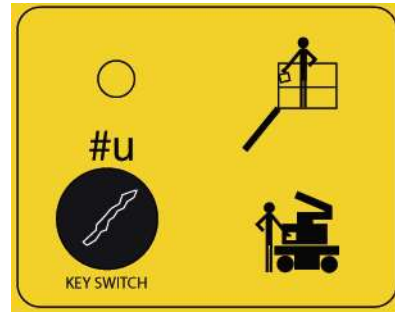

#u

TURNABLE KEY SWITCH
WITH 3 POSITIONS



= Off

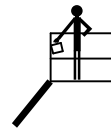

= Operate from the control panel in the basket.



= Operate from the chassis control panel.

Supplement C

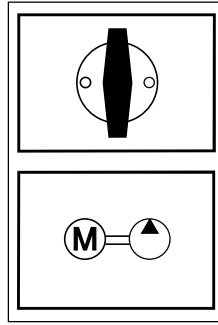

Pic. I
Battery Main Switch



Pic. II
Outrigger Indicator



Pic. III
Emergency kit with standard handle (green frame = for track version)



Pic.IV
Emergency tools

Supplement D

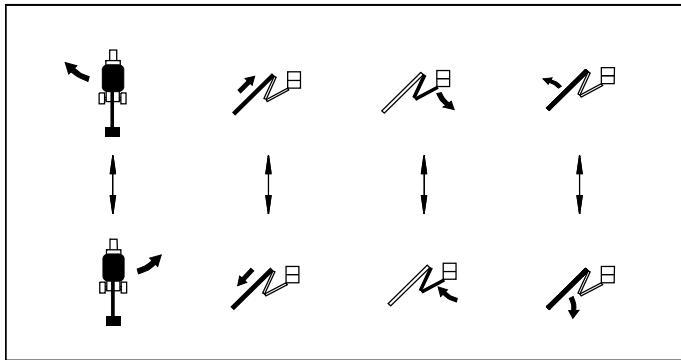

Decal for Emergency lowering at turret

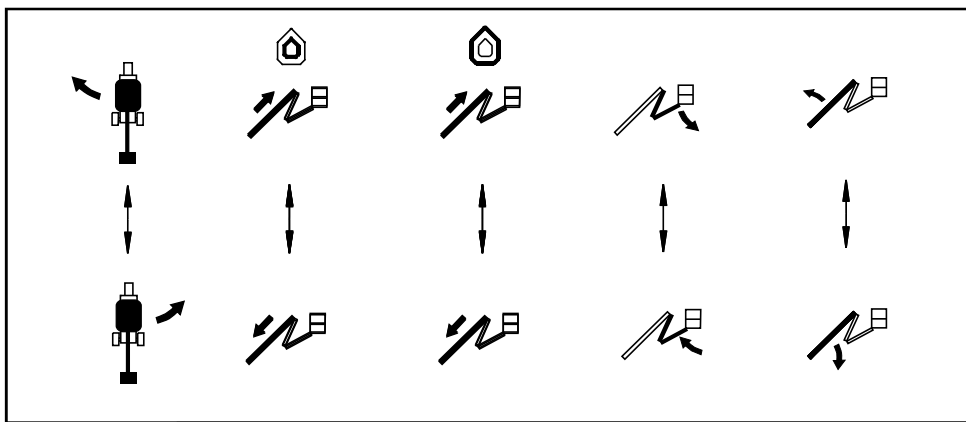

Decal for Emergency lowering at turret FS520C/FS170C Lifts

Supplement E

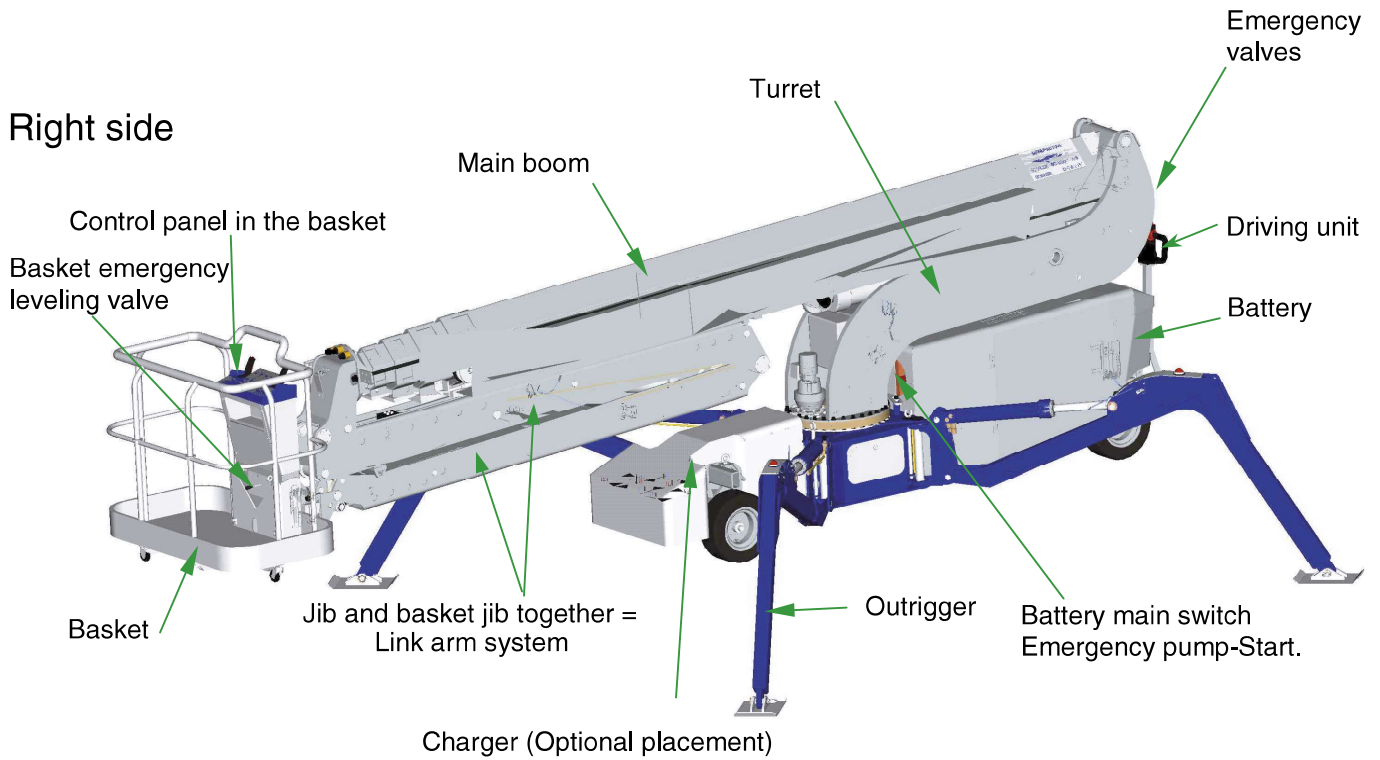

Left side

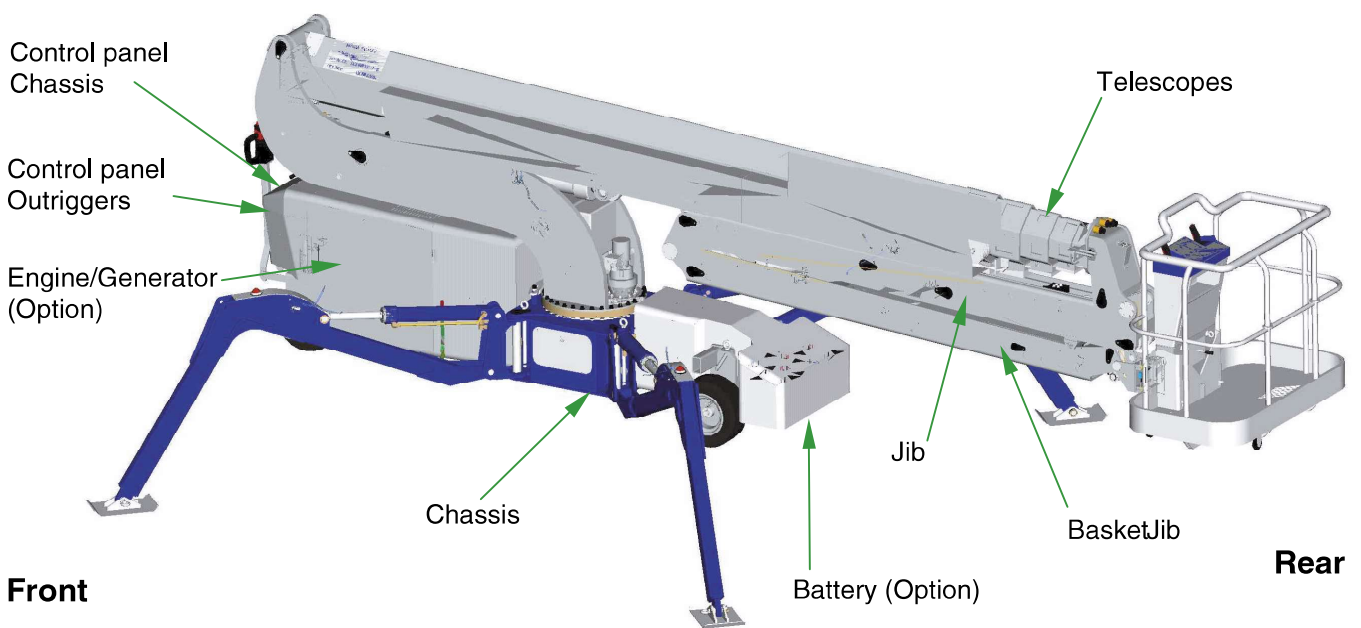

3.0 Electrical equipment

In this chapter you will find:

- **Engaging the electrical system**
- **Stability system**
- **Controls on the platform**
- **About the charger**
- **Basket rotator (Option)**
- **Acoustic signals**

WARNING

Do not attempt to open any boxes containing electrical components when power is connected to the machine. The mains supply can cause injury or death. Before opening the boxes containing electrical components the mains must be disconnected from the machine. Repair work with 24V DC power connected may only be performed by authorised personnel.

3.1.01 Engaging the electrical system

The platform is equipped with a main switch, which is located at the right side of the platform, next to the switch for the emergency pump.

Turn the main switch to position "ON".

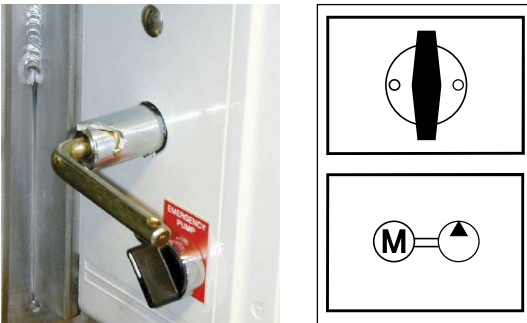
**3.1.02 Choice of control**

The platform can be operated from the Chassis control panel (suppl. A) or from the control panel in the basket (suppl. B).

The key switch (#u) for choice of control panel is located at the Chassis control panel (suppl. A).

Remove the key to prevent unauthorised use of the platform.

When the key switch (#u) is in position O, the platform is turned off.

By turning the main switch to position,



the red indicator lights on the outriggers shall light up when the outriggers are in stowed position or without a load. Always check the red indicator lights (Stability system) at the outriggers before starting to work.

When the lift is switched on it starts to undergo a test to check that no valves are stuck. While this check is performed (approx. 10 sec.) no lift functions can be used.

WARNING

Do not attempt to use the platform if red indicator lights at the outriggers are not ON, when the outriggers are in the stowed position or without a load.

If the red "STABILITY" indicator lights are out when the outriggers are lifted from the ground, the safety system has a malfunction.

Failure in the safety system can cause injury or death.

Call an authorised service centre immediately.

3.1.03 Stability system

The platform is equipped with an automatic system by which mechanical/electrical measurement secures that the platform always has the minimum required stability.

If the minimum required stability is reached the platform automatically "CUTS OUT" the functions that would reduce the stability further. During minimum stability:

"CUT OUT" the red indicator light at the outriggers with minimum pressure, will come on and the red indicator light "STABILITY" at the Basket control panel (Suppl. B) and at the Chassis control panel (suppl. A) will also come on.

If only the red indicator light "STABILITY" at the Basket control panel (Suppl. B) and at the Chassis control panel (suppl. A) comes on, a secondary "CUT OUT" stability system is activated and notices deflection of the main boom.

The only functions that are free during "CUT OUT" and secondary "CUT OUT" will be:

**RETRACT TELESCOPE
MAIN BOOM UP**

These functions will increase the stability.

WARNING

Do not attempt to use the platform if red indicator lights at the outriggers are not ON, when the outriggers are in the stowed position or without a load.

If the red “STABILITY” indicator lights are out when the outriggers are lifted from the ground, the safety system has a malfunction.

Failure in the safety system can cause injury or death.

Call an authorised service centre immediately. injury or death.

Call an authorised service centre immediately.

3.1.04 Controls on the platform (Movements and outriggers)

Chassis control panel (suppl. A)– Active:

By turning the key switch (#u) at the control panel to Position Chassis  the Chassis control panel (suppl. A) is active, and can control the movement of the main boom, telescopes, slewing, jib and basket jib by the push button.

The outriggers are controlled by hydraulic valves, activated by the control handles marked 1, 2, 3, and 4 according to the outriggers numbers, located under the chassis control panel – Outriggers at the front of the platform.

Driving the platform are done by the driving unit or the portable control box.

Control panel in the basket – Active:

By turning the key switch (#u) at the control panel to position Basket 

The Basket control panel (Suppl. B) is active, and controls movement of the main boom, telescopes, slewing, jib and basket jib, and as option, outriggers and driving functions by the joysticks and selector switches.

3.1.05 Charge indicator

On the charging box, under the cover in the rear end, you'll find small lights (LED).

When the charger is connected to the mains, the “ON” LED will flash for about 5 seconds. In these first 5 seconds the charger reads all input signals and calculates the necessary output voltage. After 5 seconds the charger will switch on, and the “ON” LED illuminates.

There are also LEDs for the following functions

- Charge voltage
- Charge current
- Boost
- Equalise
- Float charge
- Failure

If lithium system on the lift a display on the charger writes the informations

3.1.06 Battery capacity Indicator (Supplement A, #b)

The battery capacity indicator is located at the Chassis control panel (suppl. A).

The battery capacity indicator displays the capacity of the battery system in 9 levels of capacity, which are indicated by digital steps (Yellow lights).

When the capacity is below 50%, the remaining 3 yellow lights and an indicator light at the Basket control panel (Suppl. B), shines continuously, to indicate the capacity of the battery system is low. It is important to charge the battery system now.

One yellow light for every 10% capacity.

Red light indicates capacity below 20%.

CAUTION

Do not operate the platform if capacity is below 20%.

After long distance travelling you must secure that there is enough capacity to work with the platform, otherwise you must recharge the battery.

If the lift is equipped with Lithium batteries the State of Charge (SoC) is shown in percentage. on the Battery capacity indicator.



3.1.07 Basket rotator (Option)

The platform can as optional be equipped with a basket rotator, which can be controlled by the Basket control panel (Suppl. B) and from the Chassis control panel (suppl. A).

3.1.08 Acoustic signals

The platform is equipped with an acoustic pulsing signal when using the chassis functions (Driving and outriggers functions).

A slope alarm gives an increasing pulsing acoustic signal, when the chassis reach a dangerous angel (There is danger that the platform will turn over) according to horizontal.

4.0 Hydraulic equipment

In this chapter you will find:

- **A short description of the hydraulic equipment**

4.1 Hydraulic equipment

4.1.01 Power transmission

The platform is equipped with an oil pump which is driven of the 24V DC motor.

Furthermore proportional valves, filters and the oil tank in the turret section enables power transmission and a hydraulic oil pump driven by a diesel engine.

4.1.02 Activation of main boom Telescopes, jib, basket jib and basket rotator

Movements of main boom and link arm system are done by hydraulic cylinders. Telescoping is done by hydraulic cylinders and a chain system.

A hydraulic actuator does the movement of the basket rotator (Optional).

WARNING

If a chain is too slack, the platform should be brought to the ground immediately. Operating the platform with a broken chain, can cause injury or death. Call an authorised service centre immediately.

4.1.03 Activating outriggers

4 pcs. hydraulic cylinders provide movements of the outriggers (Vertical).
The cylinders have safety valves.

4.1.04 Controls of the platform

The platform can be operated from the Chassis control panel (suppl. A) located at the front of the platform or from the Basket control panel (Suppl. B).

A turnable key switch located at the Chassis control panel (suppl. A, #u), does the selection of control panel.

4.1.05 Basket locked

If the basket tilts more than 10° it will automatically secure its position. If possible move the main boom or the Link arm system in the opposite direction, until the basket is back at horizontal level.

4.1.06 Basket levelling

The basket is levelled by a hydraulic/electronic levelling system supplied from a separate 24 V DC oil pump.

WARNING

Follow the safety instructions carefully.

4.1.07 Emergency lowering

In case of electrical fault or in emergency situations the platform can be operated manually by the emergency (hydraulic) valves located at the turret.

WARNING

When operating the platform from the ground by engaging the hydraulic valves directly the safety system is not functioning and the operator must pay highly attention to every move and follow the emergency lowering procedure. "Telescopes In" is the only function to be used until the telescopes are fully retracted. Failure to do so can cause injury or death. Call an authorised service centre immediately.

5.0 Operators Instructions

In this chapter you will find:

- **Operators Instructions**
- **Driving the platform Self-propelled with driving unit**
 - Wheel Models until 105 ft
 - Sections marked blue
- **Driving the platform Self-propelled with portable box**
 - Crawler Models and wheel models taller than 105 ft
 - Sections marked green
- **Driving the platform from the transportable driving unit**
- **Setting up the outriggers from Chassis control panel**
- **Setting up the outriggers from the Basket control panel**
- **Setting up outriggers automatically (Option)**
- **Stowing the outriggers**
- **Mounting the basket**
- **About the diesel engine**
- **Operating the platform**
- **Joystick description**
- **Basket control panel Description**
- **Chassis control panel Description**

5.0.1 Drive (moving the Falcon around)

WARNING

Do not attempt to drive the lift if the axles are not completely out or completely in. The platform may tip over, causing serious injury or death.

WARNING

When driving the platform with the axles in the stowed position, keep the platform on hard, flat ground and in low speed. If the platform is driven on a slope it can tip over and cause injury or death.

IMPORTANT

Use the widest axle width possible at all times.

Be extra carefull if driving accross a slope. Turn out the outriggers and lower them to a position just over the ground. This will avoid the Falcon to tip over the side if slope is too steep.

Driving up- or down a slope always drive with the front steering wheel/s at the highest point on the slope.

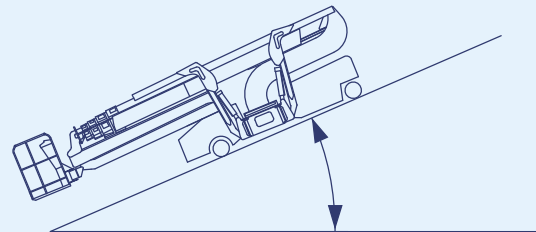

5.1.**5.1.03 Change the axle width****Wheel models until 105 ft**

The axle width of the rear set of wheels is adjustable in four positions:
0,79 – 1,02 – 1,20 – 1,40 m.
(2,6 ft. – 3,35 ft. – 3,9 ft. – 4,6 ft.)

1. To change the axle width on the rear set of wheels, place the outriggers in standard position-**green** for axle width:
0,79 – 1,02 – 1,20 m. (2,6 ft. – 3,35 ft. – 3,9 ft.)
Place outrigger 2+3 in **Yellow** position for axle width 1,40 m. (4,6ft) (See section 5.2)
2. Lift all three wheels off the ground by the outriggers (See section 5.2)
3. Remove locking pin (A) for rear axles.
4. Adjust the axle width to the needed by pushing/pulling the handle (B) at the guide for axle width.
5. Lock axle position with locking pin (A).

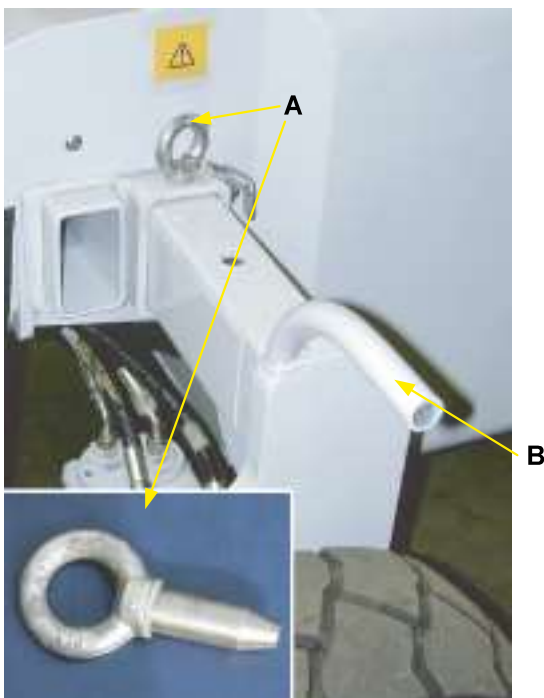

Locking for axle width.

Rear wheel – Axle width

Always use the maximum possible axle width that space allows.

WARNING

When the rear axles are not locked with the locking pin, the rear axle can fall out and the platform may tip over, causing serious injury or death.

Wheel models above 105 ft

The axle width of the rear set of wheels is adjustable in two positions:

1. completely out
2. completely in (narrow/stowed)
 1. Lift all wheels off the ground by the outriggers (See section 5.2)
 2. Turn the switch for the electrical emergency pump on.
 3. Move the handle until both axles are completely out or completely in.

**WARNING**

Do not attempt to drive the lift if the axles are not completely out or completely in. The platform may tip over, causing serious injury or death.

WARNING

When driving the platform with the axles in the stowed position, keep the platform on hard, flat ground and in low speed. If the platform is driven on a slope it can tip over and cause injury or death.



IMPORTANT

Use the widest axle width possible at all times.

5.2**Setting up the outriggers
General**

Before using the chassis functions (Driving and outrigger functions):

Retract the telescopes completely.
Fold in the link arm
Main boom in centre (The **green** information signal (E) at the control panels lights up).
Main boom down.

1. Make sure that the battery main switch is in position "ON". The battery main switch (Suppl. C, Pic. I) is located at the side of the platform next to the switch for the emergency pump. Always remember to keep the platform connected to mains if possible.
2. When using the functions according to the chassis (Driving and outriggers) the platform gives an acoustic pulsing signal.
3. To set up the outriggers from Chassis control panel (suppl. A) turn the key switch (#u) to position  for Chassis Control.
4. To set up the outriggers from Basket control panel (Suppl. B) turn the key switch (#u) to position  for Basket Control.
5. When the key switch at the Chassis control panel (suppl. A) is in position Chassis control or Basket Control. The **red** light on all 4 outriggers and the **red** "stability" indicator light, on the platform control panels, at the chassis and in the basket, must be on when the platform is in stowed position or if the outriggers are without load.
Make sure always to check the **red** "Stability" indicator lights while the platform is in stowed position.

WARNING

Do not attempt to use the platform if the **red** lights on the outriggers or the “STABILITY” indicator lights are not **ON** when the outriggers are in stowed position or the outriggers are without a load.

If the **red** “STABILITY” indicator lights are out when the outriggers are lifted from the ground the safety system has a malfunction.

Failure in the safety system can cause injury or death.

Call an authorised service centre immediately.

6. Mount the outrigger plates at the outriggers: Turn the outriggers away from the platform by lifting the locking bolts and turn the outrigger away.



Fig. 9 Locking bolt



Fig. 10 Locking bolt lifted



Fig. 11 Locking pin

7. Dismount the locking pin from the axle and remove the axle.

Mount the foot plates at the outriggers and secure it with the axle and locking pin



Fig. 12 Outrigger turned away from the platform



Fig. 13 Locking pin



Fig. 14 Foot plate mounted and secured



Fig. 15 Axle and foot plate

WARNING

Outrigger plates must always be mounted at the outrigger and secured before attempting to lift the platform off the ground.

8. When the four outrigger plates are secured the outriggers must be placed and secured/locked with the locking bolt.

WARNING

Setting up the platform on soft ground can make the platform unstable and cause serious injury or death.

Only set up the platform on hard flat ground.

Load applied to the ground is given in the technical data.

Setting up the outriggers – General

9. Each outrigger can be placed in three different positions. The outreach of the platform depends of the load in the basket and the

positions of the outriggers.
(See outreach diagram)

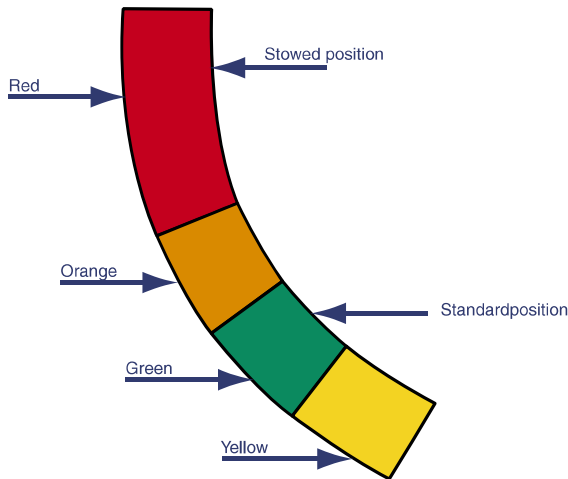

Fig. 16 Outrigger positions



Fig. 17 Outrigger in standard position.



Fig. 18 Locking bolt

Some Z-Lifts only have one position (Green)

Fig. 16:
Transportation position **Red**. Only for transportation to achieve the min. width (Stowed position).
Position – **Orange** (30° to chassis).
Position – **Green** (45° to chassis) Standard.
Position – **Yellow** (60° to chassis).

Fig. 17:
Outrigger base on chassis frame.

Fig. 18:
Locking bolt. Locking bolt must always be in position before attempting to set up the platform on outriggers.

8. Place the outriggers in the best possible horizontal position. If possible use the standard position – **Green** (45° to the chassis) and always lock with the locking bolt to the chassis frame.

The outriggers must as a minimum be in position – **Orange** before the outriggers are lowered, otherwise the outriggers will collide with the chassis.

When the four outriggers have been placed and secured/locked to the chassis frame the outriggers can be lowered by the outrigger control handles placed underneath the Chassis control panel (suppl. A) or by the Basket control panel (Suppl. B) (Option).

CAUTION

When lowering the outriggers make sure that there is no interference with the pumps and diesel engine. Do not lower the outriggers when they are locked in the stowed position. This is not a working position and can cause interference with chassis resulting in structural damage.

WARNING

When lowering the outriggers, do not lift the platform more than 2 ft. from the ground. The platform does not stop automatically. Failing to do so can cause injury or death.

WARNING

If the outrigger base of the outrigger is not locked to the chassis frame the outriggers can turn, resulting in instability which can cause injury or death. Locking bolt for securing the outrigger base to the chassis frame must always be in position before attempting to lift the platform off the ground.

5.2.01 Setting up the outriggers from Chassis control panel (suppl. A)

Overview operations locations

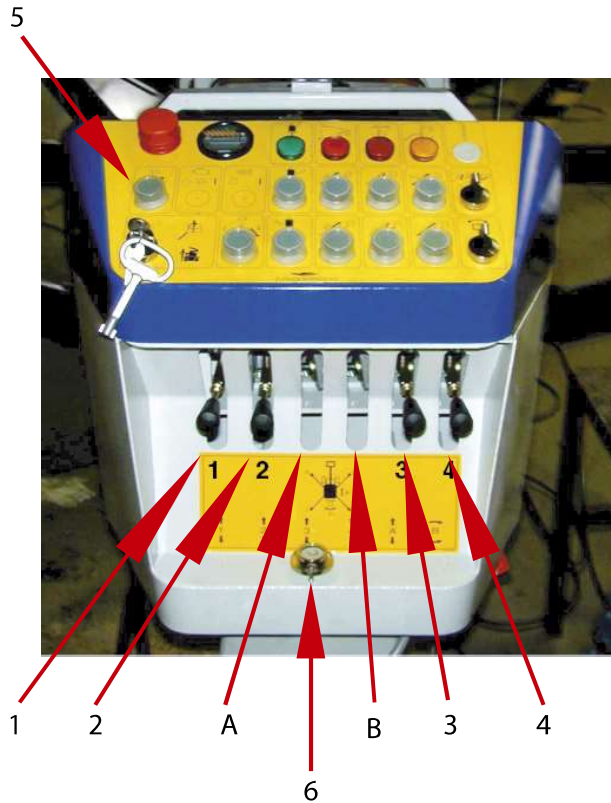

Fig 19a Outrigger control handles at crawler models

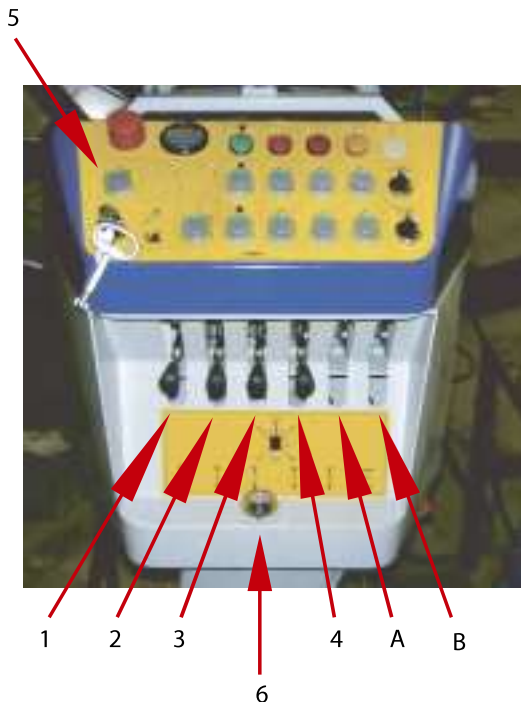

Fig 19b Outrigger control handles at wheel models

Description:

- 1 Outrigger control-handle for outrigger 1 up/ down
- 2 Outrigger control-handle for outrigger 2 up/ down
- 3 Outrigger control-handle for outrigger 3 up/ down
- 4 Outrigger control-handle for outrigger 4 up/ down
- 5 Push button for START PUMP
- 6 Spirit level

On crawler models:
(Fig 19a)

- A. Turns the tracks to the right - forward or backward.
(Handle not mounted, only for emergency)
- B. Turns the tracks to the left - forward or backward.
(Handle not mounted, only for emergency)

On Z-lifts the valves for Tracks Forward/ backward are placed inside the sandwich. The function of the Valve placed between the outrigger valves is for Track width adjustment.

WARNING

Only adjust Track width when the tracks are free of ground.

On wheel models:
(Fig 19b)

- A. Driving the platform forward/backward
(Handle not mounted, only for emergency)
- B. Valve for turning the front wheel clockwise/ counter-clockwise
(Handle not mounted, only for emergency)

Setting up the outriggers from the chassis

To set up the outriggers do as followed:

1. Place the outriggers in the chosen position.
2. Turn the key switch at Control panel-Chassis

to position chassis. 

3. Push the button **START PUMP** (#h) at the Chassis control panel (suppl. A).

4. Bring the outriggers to the ground by the control handles.

It is recommended to bring all 4 outriggers in contact with the ground one by one.

5. Lower the outriggers two at the time (1 and 4 together - 2 and 3 together) by the outrigger control handles to give an equal pressure on each outrigger.

6. The platform shall be lifted from the ground until all tracks/wheels no longer have contact with the ground.

When the outriggers are pressed to the ground the **red** stability indicator lights, at the outriggers shall turn off.

7. When setting up the outriggers, the platform must be on hard flat ground. Make sure the platform is in horizontal level by checking the spirit level located at the chassis frame.



Fig. 20 Spirit level

WARNING

When positioning the outriggers on the ground it is important to ensure that all limbs are kept clear of the outriggers, outrigger plates and any other moving parts.

Failing to do so can cause injury or death.

WARNING

Setting up the platform out of horizontal level to the ground can give instability and cause injury or death.

The platform must be set up with chassis in horizontal level.

The outreach of the platform depends on how the outriggers are placed. Wider outrigger span and lower basket load means longer outreach.

In order to achieve the maximum working height the platform must be raised 2 ft off the ground measured from the ground to underneath the wheels. (see outreach diagram)

Pay attention to the free rotation of the turret!

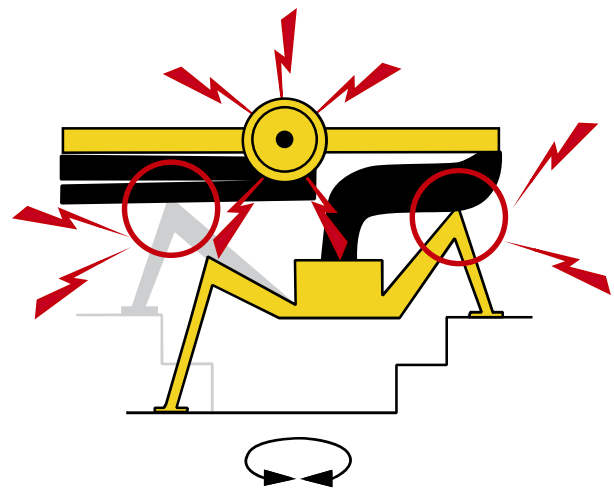



5.2.03 Setting up outriggers automatically (Option)

As option the outriggers can be set up automatically in horizontal level and the pressure in the hydraulic system equalised by the remote control panel

It is recommended only to use automatic set up for the outriggers at horizontal surfaces and with the outriggers in standard position (45° to chassis – **Green**).

1. Bring the outriggers in position, and lock them with the locking bolt.
(According to the procedure in section 5.2)
2. Push the button (#v) continuously and the outriggers will be set up.
3. The platform is in horizontally level and the pressure in the hydraulic system of the outriggers is equalized when the **green** Information signal (C) starts flashing, and the operator can now release the button (#v).
4. If the platform needs to be lifted higher from the ground repeat procedure 2 and 3.

To lift the outriggers from the ground use the control handles for the outriggers (Chassis control panel or the joystick (Control panel – Basket)).

WARNING

Do not attempt to use the platform if the **red indicator lights at the outriggers are not ON, when the outriggers are in stowed position or the outriggers are without a load.**

If the **red “STABILITY” indicator lights are out when the outriggers are lifted from the ground, the safety system has a malfunction.**

Failure in the safety system can cause injury or death.

Call an authorised service centre immediately.

5.2.04 Stowing the outriggers

The outriggers can be stowed in the following order:

1. Retract the telescopes
2. Fold in the link arm system
(The jib and basket jib)
3. Main boom in centre
4. Move the main boom down
5. Leave the basket
6. Dismount the basket, if needed
7. Lift the outriggers from the ground two by two (1 & 4 together - 2 & 3 together) by the outrigger handles
8. Remove the outrigger plates if needed.
9. Bring the outriggers in stowed position and lock them with the locking bolts

In order to achieve the minimum height, width and length according to the technical data, the basket and the outrigger plates must be dismantled and the outriggers placed in stowed position (**Red**).

WARNING

Do not set up the platform, when the outriggers are in **Red position (Suppl. C, Pic II) (Stowed position).**

This is ONLY transport position.

Failing to do so can be a cause for injury or death.

5.3 Before using the platform

5.3.01 Mounting the basket

1. Mount the basket at the two brackets (A) at the console for the Basket Control Panel.
2. Secure the basket with the two locking pins (B)
3. Safety belt can be mounted at the two fixing-points (C)

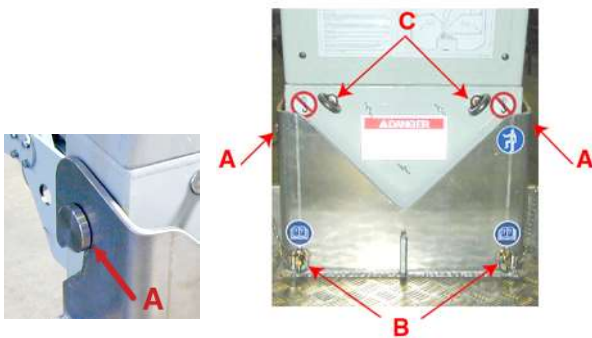

Fig. 22 Mounting the basket

WARNING

When mounting the basket make sure that the basket is locked properly. A basket not locked properly can fall of and cause injury or death.

WARNING

When the platform is used for welding work the platform has to be unplugged and the outriggers have to be placed on rubber mats.

5.3.02 Power supply

If mains are not available it is possible to work without being connected to the mains outlet. To avoid discharging the batteries the battery charger shall, if possible, always be plugged in.

Optional:
 24V DC motor and diesel engine.
 Diesel engine (option on wheel models)
 AC motor (option).

5.3.03 Diesel engine (Optional for wheel models)

The platform, if equipped with a diesel engine, it can be started and stopped from the turnable switch on the Chassis control panel (suppl. A, #i) or at the Basket control panel (Suppl. B, #i)

The turnable switch (#i) have 3 positions

O = Diesel engine stopped

☆ = Ignition for diesel engine

I = Diesel engine starter/preheater

The turnable switch comes on red when the diesel engine is started. If the red light flashes in the turnable switch the fuel level is low. Refill fuel as soon as possible.

By turning the switch (#i) to I, hold it till it starts (app. 30 seconds). The engine is preheating before it starts.

By turning the switch (#i) to ignition and not starting the engine, it will after app. 10 sec. automatically cut of. After this it is necessary to turn the switch (#i) back to position O and then to position I.

REMARK: The turnable switch (#i) activates only the functions by change.

As an example:

If the diesel engine is operated from the Chassis control panel (suppl. A) turn the key switch (#u) to position Chassis and turn the switch (#i) to position I. When the diesel motor starts let go of the switch (#i), and the switch returns automatically to ignition position. The switch (#i) at the Basket control panel (Suppl. B) will still be in position O. The red light in the switch will come on to indicate that the motor is running. To turn off the engine from the Basket control panel (Suppl. B) turn the key switch (#u) to position 

Turn the switch (#i) to position  and then to position O and the motor will stop/turn off.

Diesel engine (Lombardini)

The information lights for the diesel engine are placed at the end of the platform



Fig. 23



1. Air filter. The light comes on when the filter is blocked

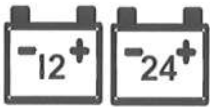

2. 12V/24V generator. The light comes on when there is no charging to the 12V/24V generator



3. Oil pressure. The light comes on when oil pressure of the diesel motor is too low



4. Water temperature. The light comes on at high temperature

When the diesel engine is running it will charge the batteries of the platform.

When the diesel engine is running all functions of platform will be power supplied from the diesel engine.

Other pumps will not be started

Service- and maintenance of the diesel engine is according to the Operators instructions for the Lombardini diesel engine.

Generator (Honda)

If a generator (available as option) is mounted, it is operated from the control panel located at the generator.

When using the generator, place the plug (see picture below) in one of the AC receptacles, and the generator supplies the battery charger, and the mains outlet in the basket.



Plug

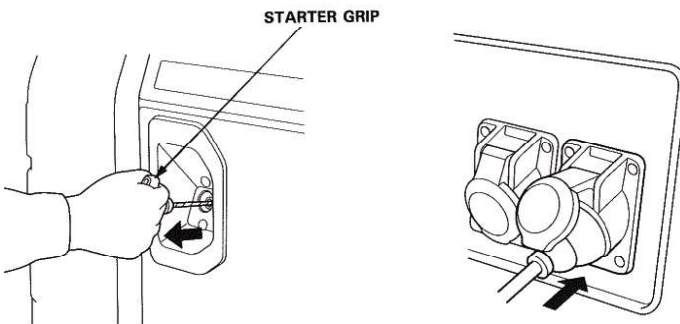
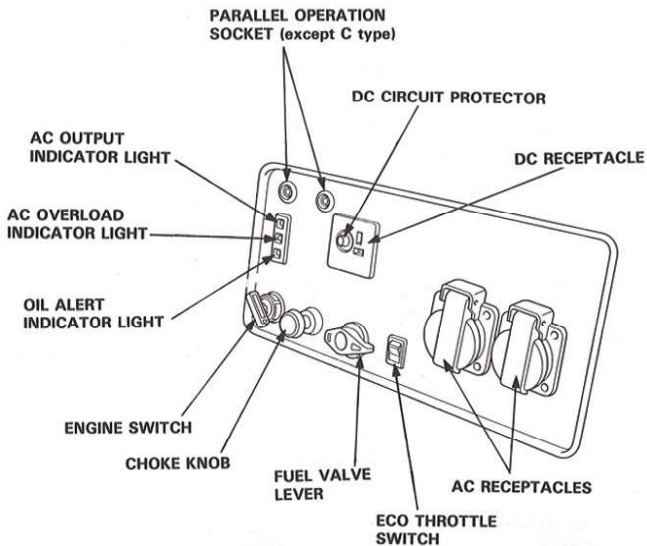

1. Turn the fuel valve lever to ON position.
2. Pull the choke knob out to closed position.
NOTE: Do not use the choke when the engine is warm or the air temperature is high.
3. Push the Eco throttle switch to position OFF.
4. Turn the engine switch to ON.
Turn the engine switch shortly to starting position.
5. If there is no battery capacity or at models with manual starter:
Pull the starter grip lightly until resistance is felt, then pull the starter grip briskly.
6. Push the choke knob to the open position as the engine warms up.
7. Push the Eco throttle switch to position ECO.
Please follow the instructions in the HONDA Owner's MANUAL.

5.4 Operating the platform

Personnel who needs to gain access i.e. for maintenance and cleaning operations can use the platform.
The platform is not insulated for working with or near high voltage installations and the platform may not be used for any other purpose than to give access for personnel. The platform may not be used as a crane and large objects may not be placed in the basket or at the boom i.e. large label or windows.
Contact between platform or basket and fixed objects i.e. buildings shall be avoided.

WARNING

The basket is not insulated for work with or near high voltage installation. Work in assured clear distance from electrical power lines. Failing to do so can result in electrocution causing injury or death.

WARNING

Do not attempt to climb outside the basket when it is lifted from the ground. Always make sure you use a safety belt as required by your employer or the appropriate fall protection. Falling from the platform can cause injury or death.

WARNING



Do not attempt to climb on top of the basket or to use a ladder or likewise from the basket.

WARNING

Overloading the platform can cause serious injury or death. Do not overload the basket, or attempt to use the basket or the platform as a crane.

WARNING

Before entering the basket it must be controlled that the basket is properly locked to the basket suspension. Do not attempt to use the platform without the use of a safety belt. The safety belt must be properly locked in the fixing point. Incorrect operating of procedures can cause injury or death.

1. Read the complete manual and the safety instructions, and make sure to perform the daily inspection checks before attempting to use the platform.
2. Set up the platform as according to section 5.2.
3. Make sure that the battery main switch (Suppl. C, Pic. I) is in position "ON". The battery main switch is located at the right side of the platform next to the switch for the emergency pump.
4. The platform can be operated from Basket control panel (Suppl. B) or from the Chassis control panel (suppl. A) in the front end of the platform.
To operate the platform from the basket, turn the key switch (#u) located on the Chassis control panel (suppl. A) to position. 
5. To operate the platform from the ground, turn the key switch (#u) located on the Chassis control panel (suppl. A) to  position.
6. Enter the basket (max. 440 lb)

NOTICE

When operating the platform from the basket – All movements are proportional
When operating the platform from the chassis the movements have predefined speed by push buttons.

7. With the platform in stowed position use the following unpacking procedure according to the label at the Link-arm system to prevent damage to the platform:

- Raise the main boom.
- Extend the telescopes, until there is enough space to fold out the Link-arm system.
Before activating the Link-arm system and/or the Jib, the Telescopes shall be extended until there is space between the Link-arm system and the covers.
- Fold out the Link-arm system.

WARNING

Always pay attention to the position of the outriggers, turret and Link-arm system while slewing.

There can be danger of collision between outrigger(s) and Link-arm system and/or between the turret and outrigger(s).

Failing to do so can cause structural damage to the platform.

WARNING

When folding out the Link-arm system, make sure there is no collision between the Link-arm system and the cover(s).

Raise the main boom and extend telescopes before folding out the Link-arm system.

Failing to do so can cause structural damage to the platform

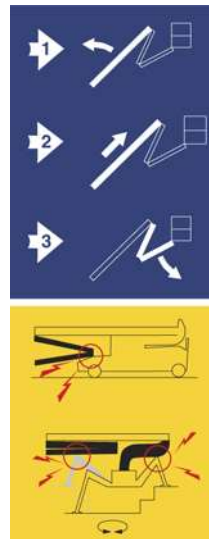

Fig. 24 Label for the unpacking procedure located at the Link-arm system and turret.

5.4.02 Basket control panel

Description of the functions (Suppl. B)

Chassis functions and PLATFORM functions

1. Caution signal – **LOW BATTERY CAPACITY**

When the **red** light (#w) comes on the capacity of the battery is below 50%.

If it flashes it means that the charger is not connected or it indicates a fault. Please check the charger.

If the charger is connected and the **red** light still shines leave the platform momentarily and let it charge the batteries.

If the platform is equipped with a diesel engine, it can be started.

2. Warning signal – **STABILITY.**

If the **red** stability light (#d) on the basket control panel comes on and the platform functions stops the main reason is that the limit for sufficient stability is reached. (This is normally caused by maximum outreach with the given basket load compared to the span of the outriggers)

As long as the **red** lights are shining only the functions that increase stability can be used:

RETRACT Telescopes #s
MAIN BOOM UP #n

3. Warning signal - **Basket LOCKED**

If the basket tilts more than 10° it will automatically secure its position and the **red** light (#e) comes on. If possible move the main boom or the Link arm system in the opposite direction, until the basket is back at horizontal level and the **red** light turns off.

(section 6.1.01)

4. Caution signal – **MOVEMENTS BLOCKED**

If the light comes on (#f) the basket jib is out of it's allowed working area (vertical) either upwards or downwards.

Only functions bringing it back to allowed working area can be used now.

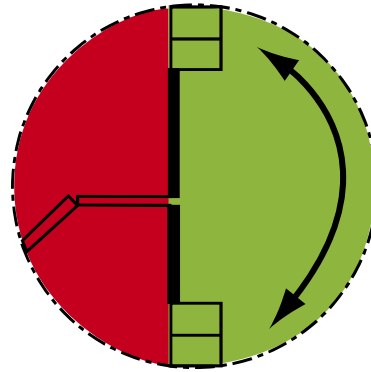

Fig. 32 Movements blocked
Green area is allowed working area.

5. Warning signal – **Basket OVERLOAD**

If there is an overload of the rated basket load the light (#g) will flash.

6. **Diesel Engine**

By turning the switch (#i) to I, hold it till it starts (app. 30 seconds). The engine is preheating before it starts.

By turning the switch (#i) to ignition and not starting the engine, it will after app. 10 sec. automatically cut of. After this it is necessary to turn the switch (#i) back to position O and then to position I.

7. **EMERGENCY STOP BUTTON.**

To release the Emergency stop button (#a) pull it.

8. **MAIN BOOM in Centre**

Information signal (#c). When the main boom is in centre, the **green** light will come on. Every time the main boom passes the centre the **green** light will come on for a few seconds. (Option)

This light is also used for auto set up. See point 9.

9. AUTO SET UP Outriggers (Option)

Push button (#v) automatically sets up the outriggers at horizontal level and equalises the pressure in the hydraulic system of the outriggers.

It is recommended, only to use automatic set up for the outriggers at horizontal surfaces and with the outriggers in standard position. (45° to chassis – green position at the label)

1. Bring the outriggers in position, and lock them with the locking bolt.
(According to the procedure in section 5.2)
2. Push the button (#v) continuously and the outriggers will be set up.
3. The platform is at horizontal level and the pressure in the hydraulic system of the outriggers is equalised, when the green information signal (#c) starts flashing. The operator can now release the button (#v).
4. Does the platform need to be lifted further from the ground, repeat the procedure 2 + 3.

5.4.03 Chassis control panel Description (suppl. A)

1. Turnable key switch (#u) with 3 positions:

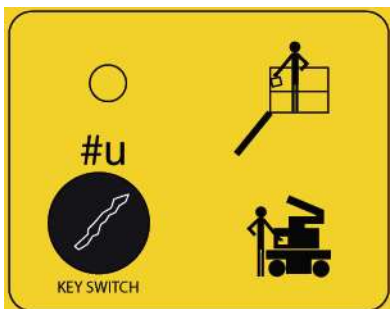



Fig. 33

O = Off

 = Operate the platform from the control panel in the basket.

 = Operate the platform from the control panel at the Chassis.

When operating the platform from the basket, it is recommended to remove the key to prevent unauthorised use of the platform.

2. Push button.
(#h) Start the pump for the outriggers.
3. Emergency stop button.
To release the Emergency stop button, (#a) pull it.
4. Turnable switch (3 positions)
ON/OFF for the diesel engine (#i)

For turning the diesel engine on, turn the switch to position I.

(By turning the switch to I, hold it till it starts (app. 30 seconds). The engine is preheating before it starts.

By turning the switch to ignition and not starting the engine, it will after app. 10 sec. automatically cut of.

After this it is necessary to turn the switch back to position O and then to position I.)

When the engine is running release the switch and it'll turn back to the middle position and the white light in the switch shines. If the white light is flashing, the fuel level is low.

To stop the diesel engine, turn the switch to position O

5. BATTERY INDICATOR.

(#b)

See 3.1.07

6. 220V pump. (Option)
(#j)

7. Information signal – MAIN BOOM IN CENTRE

Information signal (#c). When the main boom is at centre, the green light will shine. Every time the main boom passes the centre the green light will shine for a few seconds.

This light is also indicating when the outriggers are at horizontal level. (Option)

When setting up the outriggers automatically, the information signal (green light) will flash when the outriggers are in horizontal level and the pressure in the hydraulic system is equalised.

8. Warning signal – **STABILITY.**

If the **red** stability light (#d) on the basket control panel and one or more on the outriggers come on, and the platform functions stops, the main reason is that the limit for sufficient stability is reached. (This is normally caused by maximum outreach with the given basket load compared to the span of the outriggers)

As long as the **red** lights come on only the functions that increase stability can be used:

RETRACT Telescopes #s
MAIN BOOM UP #n

9. Warning signal - **BASKET LOCKED.**

If the basket tilts more than 10° it will automatically secure its position and the **red** light (#e) come on. If possible move the main boom or the Link arm system in the opposite direction, until the basket is back at horizontal level and the **red** light turns off.

(section 6.1.01)

10. Caution signal – **MOVEMENTS BLOCKED.**

If the light shines (#f) the link arm has reached it's maximum working area (vertical) either upwards or downwards. Only functions increasing the security can now be used.

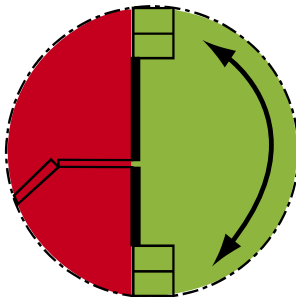

Fig. 34 Movements blocked

11. Turnable switch

(#s) Spring loaded to centre, for movement of only the **JIB** or the **Basket JIB**

If it is needed to move **only the Basket JIB**, turn the switch to the right and hold it and at the same time push one of the buttons (#p) folding in or (#o) out and the **Basket JIB** will move. To stop the movement, release the buttons.

12. Push button - **MAIN BOOM UP**

(#q) By pushing the button the main boom moves up. Release the button to stop the movement.

13. Push button - **MAIN BOOM DOWN.**

(#r) By pushing the button the main boom moves down. Release the button to stop the movement.

14. Turnable spring loaded switch for **BASKET ROTATION.**

(#t) When turning the switch, the basket will rotate depending of which side the switch is turned to. Release the switch to stop the basket rotation.

15. Push button - Movement of **LINK ARM SYSTEM.**

(#p) By pushing the button the jib and the basket jib are folding in. Release the button to stop the movement.

The jib and the basket jib are not moving 100% simultaneously, therefore it can be necessary to adjust the **JIB** and **Basket JIB** one by one.

16. Push button – **RETRACT TELESCOPES.**

(#n) By pushing the button the telescopes retract. Release the button to stop the movement.

17. Push button – **EXTEND TELESCOPES.**

(#m) By pushing the button the telescopes extends, release the button to stop the movement.

18. Push button – **SLEWING CLOCKWISE.**

(#l) By pushing the button the turret will slew clockwise, release the button to stop the movement.

Raise the main boom until it is in horizontal level and extend the telescopes app. ½ ft. before slewing is possible.

19. Push button – **slewing COUNTER-CLOCKWISE.**

(#k) By pushing the button the turret will slew counter-clockwise. Release the button to stop the movement.

Raise the main boom until it is in horizontal level and extend the telescopes app. 150 mm. before slewing is possible.

5.4.04 Description of the remote control



Description of the contacts (#)

#1	Start the remote control	#7	Basket Turning - left / right
#2	constant light = "ON" flashing = Low battery	#8	alternate functions are shown on the display
#3	Emergency / off (turn to reset)	#9	Selector Left - Lift features Middle - chassis Right - Outrigger function
#4	Poor radio signal	#10	Horn
#5	Diesel Engine: Left - turn off the engine Middle - Ignition Right - Preheat / start		
#6	Traction / speed belts: Left - high torque / slow driving Right - low torque / fast driving		

5.4.05 Description of Display

Display (%)

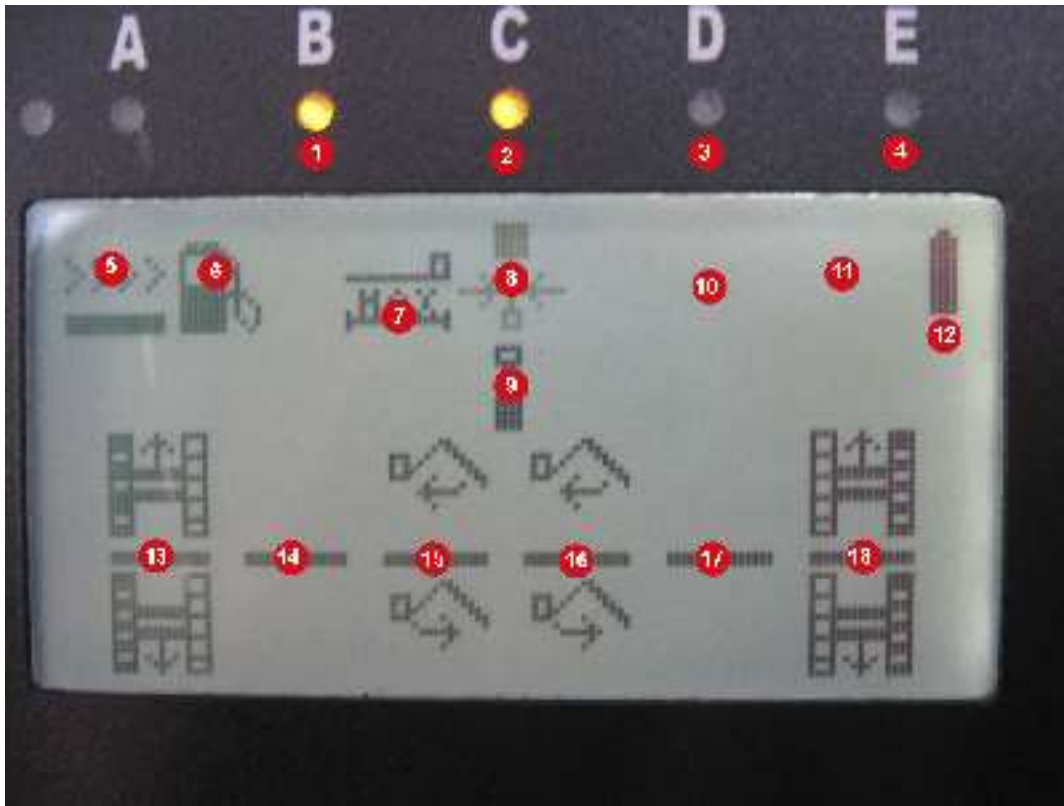

%1	LED, maximum Range		Indication Emergency stop button pressed down.
%2	LED, slewing in the center position. (Flashes when the rotation is not allowed)		Indication Basket not secured.
%3	LED, Basket locked (10 degree)	%11	Indication IDRC Turn to occupy a better position relative to the basket (Only when IDRC is selected)
%4	LED Failure of the safety system	%12	Indicator Battery Level Remote Control
%5	Indication Mode Selection	%13	Indication Joystick one from the left (left belt)
%6	Indication Energy	%14	Indication Joystick second from left
%7	Indication maximum range	%15	Indication Joystick third from left (Jib)
%8	Indication Turret in the center position	%16	Indication Joystick fourth from left (Jib)
%9	Indicate direction relative to the basket	%17	Indication Joystick fifth from left
%10	Indication basket locked (10 degree) Indication movement blocked. Indication Max. windspeed	%18	Indication Joystick sixth from the left (Right belt)

Indication Mode Selection %5



Lift Function



Preheat / Starter

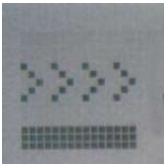

Driving (Fast speed / horizontal surface)

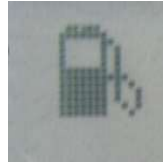

Low fuel level



Driving (Slow Speed / Increase)

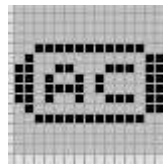

AC Motor ON



outriggers Function

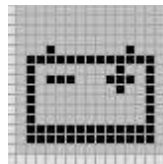

Battery level SoC <20%
Flashes if no charging.



alternate Function

No indication for 24V operation.
Indication maximum range %7

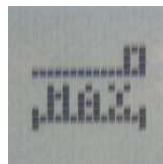

maximum range is displayed with light in
LED B (% 1)

Indication Energy %6



ignition

Indication Turet %8

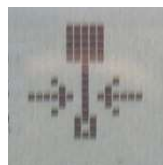

Slewing in the center position, shown together
with the LED light in C (%2)
If you slowly turn over the center
position, the slewing will stop a
moment.



Indication

Direction relative to the basket %9

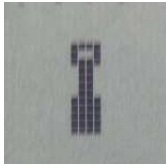

The display shows the lift viewed from the front and the basket farthest

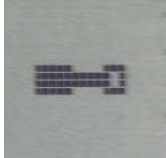

The display shows the lift seen from the left side, and the basket is to the right.
(Only with IDRC optional)



The display shows the lift seen from the basket. The front end is farthest



The display shows the lift seen from the right side, and the basket is to the left.
(Only with IDRC optional)

Indication basket locked %10

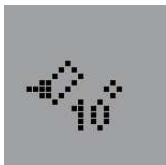

The symbol appears when the basket slopes more than 10 degrees to the horizontal, and is displayed together with the diode D (%3)

Indication movement blocked %10



The symbol appears when the basketjib has reached maximum vertical extent upward or downward. Only function which brings it back is allowed.

Indication max. Wind speed %10



This symbol appears if close to the maximum allowable wind speed

Indication Emergency stop activated %10

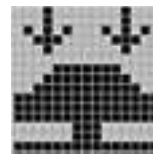

This symbol appears if emergency stop button on front panel is pushed down.

Indication Basket not secured %10

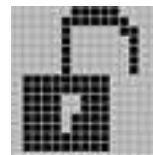

This symbol appears if the basket is not secure with correct inserted locking pins.



Indication

IDRC - Change Position %11



When the IDRC is connected, this symbol is shown. If the relative position between remote and the lift is bad. One must then rotate either right or left to achieve better connection.

Indication of battery level on the remote control %12



The battery level is displayed at 100%, 66%, 33% or 0%. At 33% the symbol starts blinking and the remote control should quickly be connected with the cable in the basket, or the battery needs replacing.

Replacing / recharging battery for remote control

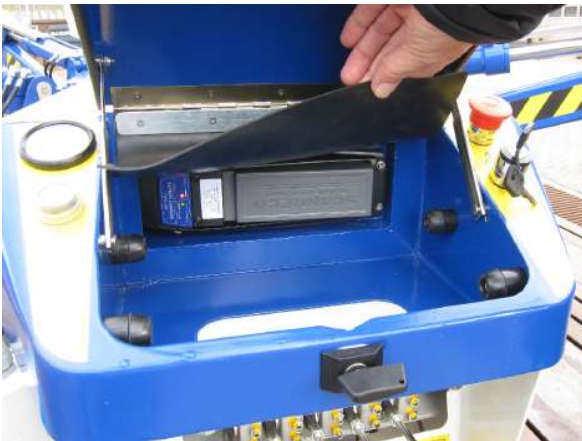

At the front of the lift where the remote control also is found, under a gated that opens with the same key used to the side guards. Here is located a charger and an extra battery.

Connecting to cable in the basket.



In the basket it is possible to connect the remote control to a cable, whereby the transmitter turns off and data will be sent directly through cable while the battery in the remote charges.

5.4.06 Startup

Turn on the main switch

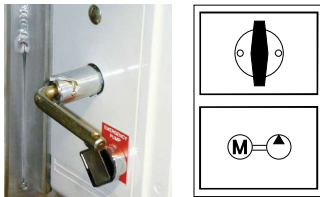

Turn the main switch to the ON position, which is located at the rear end of the lift next to the emergency pump.



Turn the key switch to the right to control the chassis or basket. (Remember if you select the control from the basket, the connector on the remote control must be mounted in the basket)

When the lift is switched on, it starts to undergo a test to check that no valves are stuck. While this check is performed (approx. 10 sec.) no lift functions can be used.



Check the battery indicator Battery level (round indicator) on the chassis control panel and also the emergency stop if it is activated. Should be disabled.

Emergency stop (# 3) on the remote control turned and released.

Start Button (# 1) held down for one second, until there is red light in the indicator (# 2). Shown below boot image is displayed for a few seconds.



Boot image with IDRC



Boot image without IDRC

5.4.07 IDRC

Depending of the selector switch(#9) position, one of the three following screens are shown.

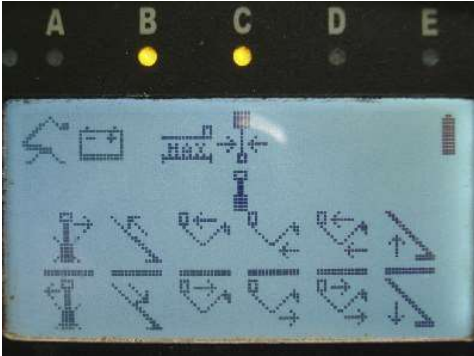

Left - Lift Function

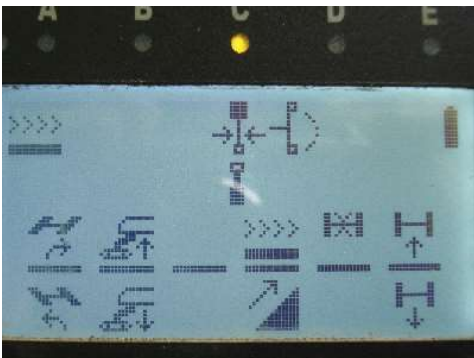

Middle - driving function

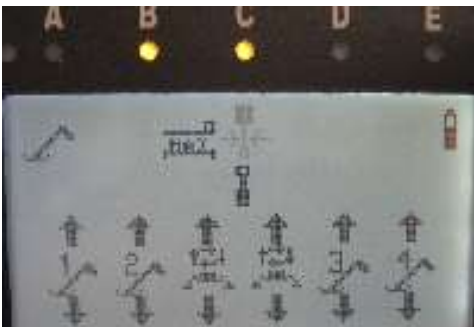

Right - Outrigger function

IDRC is a inovative system, which makes it possible to work with the remote control and the lift in an intuitive manner.

The system has two directional sensors, one on the lift, and one integrated into the remote control.

Activation

Simultaneously press the Alternative switch # 8 and the horn # 10 and bring the two right handle forward simultaneously.

Enable - Disable - Emergency Stop # 3 and press start button # 1 shot. Now comes this boot image:



Boot image with IDRC

Disabling

Simultaneously press the Alternative switch # 8 and the horn # 10 and bring the two right handle back simultaneously.

Enable - Disable - Emergency Stop # 3 and press start button # 1 shot. Now comes this boot image:



Boot image without IDRC

5.4.08 Lift Function

Function selector switch to the left position and the following image appears on the display:

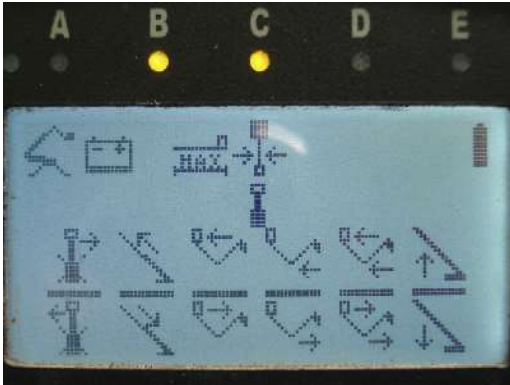

The main boom is controlled with the right handle

Both arms in the link arms are controlled simultaneously with handle No.2 from the right.

Link arm alone (nearest telescop) is controlled with handle No.3 from the right.

Jib arm alone (nearest basket) is controlled with handle No.3 from the left.

Telescope is controlled with handle No. 2 from left

Slewing is controlled by the left handle

5.4.09 driving

Before you can drive, all four outriggers must be raised from the ground.

Function switch # 9 place in the middle position.

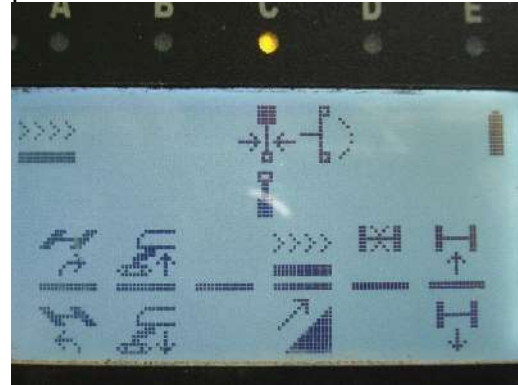

The two belts are controlled independently of each other with the left and right handle.

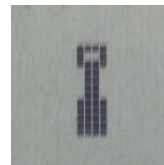

Watch for this symbol.

When having the same position relative to the basket, as the symbol shows, the lift drives away from you when lever is moved forwards.

If your position is reversed to the symbol, the lift will drive away from you when you pull the lever back.

With one of the two middle handle, the jib arm is raised or lowered.

With switch # 6 choose whether it should be fast speed with low pulling force, or slow speed with high pulling force.

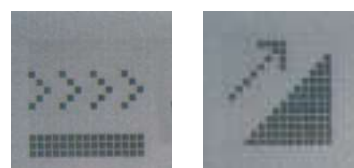

5.4.10 Setting up the outriggers from the remote control

The function selector # 9 place in the right position and the following picture is displayed.

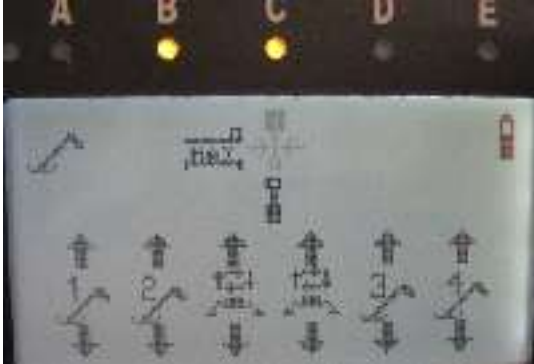

When the lift is not equipped with IDRC:

First handle from left, outrigger 1
Pull back and outrigger is lowered.
Push away and outrigger is raised up.

Second handle from left, outrigger 2
Pull back and outrigger is lowered.
Push away and outrigger is raised up.

The second lever from the right, outrigger 3
Pull back and outrigger is lowered.
Push away and outrigger is raised up.

The first lever from the right, outrigger 4
Pull back and outrigger is lowered.
Push away and outrigger is raised up.

If equipped with "Auto Set-up" the outriggers can automatically be set up at the same time by pulling back the two middle handles - at a constant tone - the lift is finished with "Auto Set-up"

Check the spirit level Fig.19 - 6

with IDRC

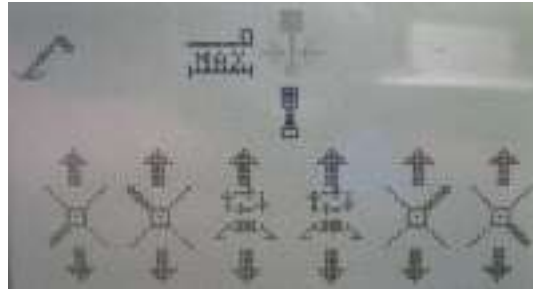

Watch for this symbol:

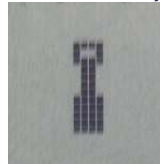

If you are in the same position as the symbol

compared to the lift, the left handle will control the nearest outrigger on your left.

Second handle from left will control the farthest outrigger on your left.

Second handle from the right will control the farthest outrigger on your right.

First handle from the right will control the nearest outriggers on your right.

5.4.11 Alternate functions from remote control.

Push down the push button #8 and keep it pressed to engage the alternate functions.

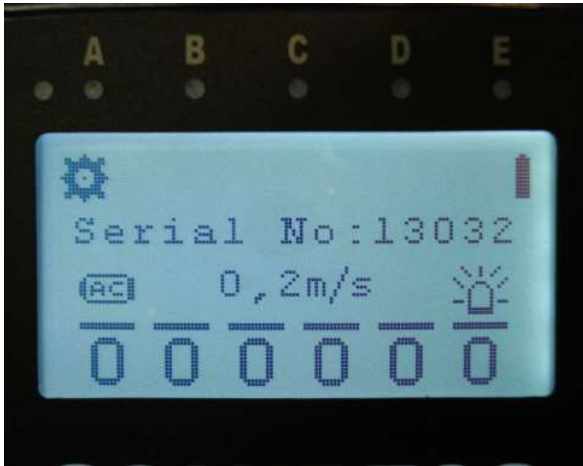

The six leavers will now work to turn on and off different functions. Moving the leaver away from operator will turn the function “ON”. Moving the leaver towards the operator will turn “OFF” the function. Depending on the options chosen different functions will appear.

Further more Serial number and machine hours are showed and if wind speed indicator is chosen also the wind speed is showed

6.0 Emergency lowering General

In this chapter you will find:

- Emergency lowering General
- Electrical pump emergency lowering
- Basket levelling (electrical)
- Emergency lowering Telescopes
- Emergency lowering Levelling (electrical)
- Emergency lowering Link arm (electrical)
- Emergency lowering Main boom (electrical)
- Emergency lowering manual hand pump

PICTURES

- Basket levelling (Manual)
- Emergency lowering Telescopes (Manual)
- Emergency lowering Levelling (Manual)
- Emergency lowering Link arm (Manual)

6.0 Emergency lowering General

In emergency situations or in case the electrical controls are malfunctioning, it is needed to use the emergency pump or manual hand pump. The platform function emergency valves are placed at the turret.

IT IS RECOMMENDED, IF POSSIBLE, TO RETRACT THE TELESCOPES FIRST.

When activating the emergency valves, the stability system is not working. See WARNING below.

WARNING

When operating the platform from the ground, by engaging the emergency valves directly, the safety system of the platform is out of function. When operating the platform directly from the emergency valves, “Telescope in” is the only function to be used until the telescope is fully retracted. Failing to do so, can cause personnel injury or death. Call authorised maintenance immediately.

It is recommended to make every move very slow to prevent damage to buildings, windows etc.

The emergency valves are controlled by the emergency lowering kit, placed in a bag, at the chassis.

The emergency lowering kit consists of four parts:

1. One Emergency handle marked **Red** to operate the basket levelling valve.
2. One Emergency handle marked **Blue** to operate the LS-valve.
3. One Emergency handle without any mark, for the movements of the platform according to the label (Suppl. D)
4. A handle for the manual hand pump/crawler hand pump.

By emergency lowering, the operator must mount one or more of the handles at the turret. The **blue** handle goes to the emergency valve marked with a **blue** dot and so on. See photo.

If there is still power at the batteries (The electrical emergency pump starts when it is activated) follow the emergency procedure (electrical) at section 6.1

If the electrical emergency pump does not start, follow the emergency procedure (Manual) at section 6.2

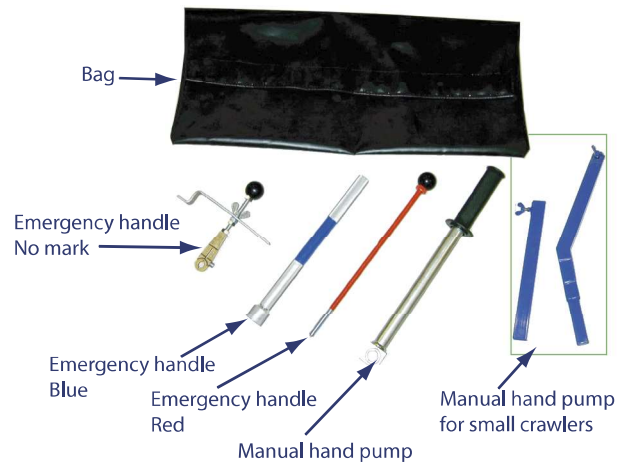

Fig. 35 Emergency lowering Kit and bag



Fig. 36 Label placed at turret, please see Suppl. D



Fig. 36a ball valve emergency basket leveling.



You will find the emergency lowering kit near this sign.

Emergency lowering – General

By emergency lowering with the electrical emergency pump is it not necessary to dismantle the cover at the platform.
 To use the manual hand pump dismantle the cover at the platform.

Left side

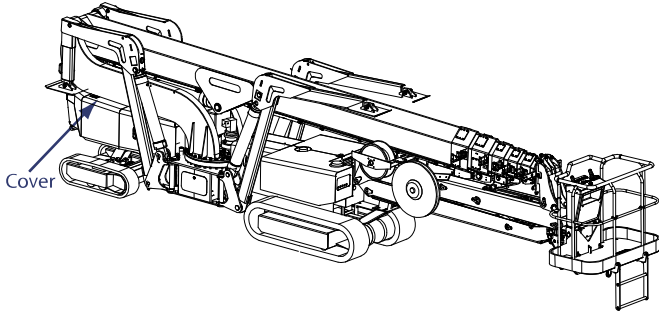

Fig. 37

Right Side

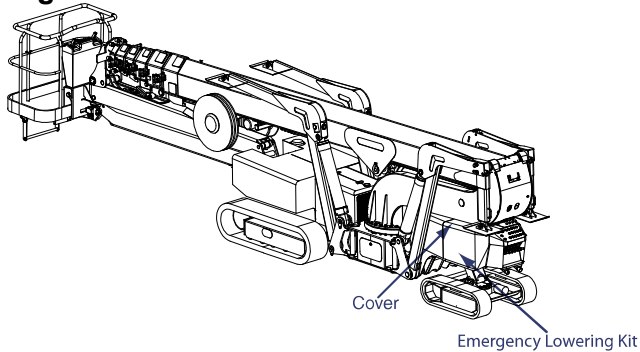

Fig. 38

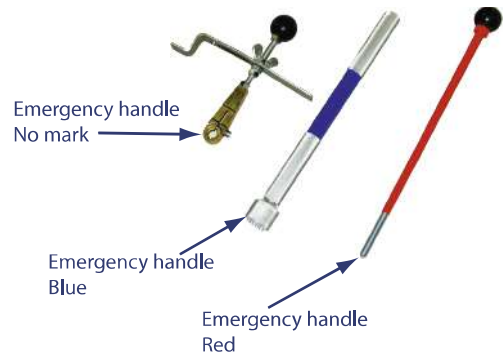

Fig. 39 Emergency tools

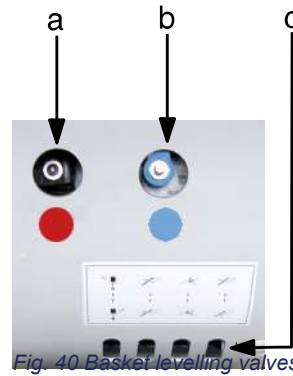

Fig. 40 Basket levelling valves

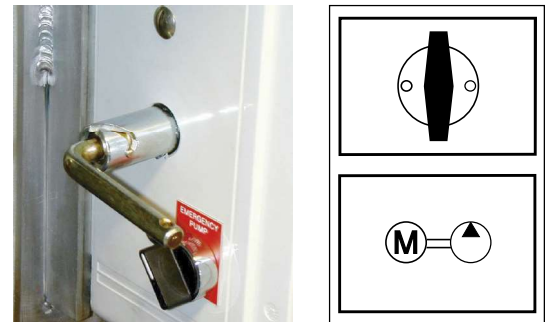

Fig. 41 Handle for electrical emergency pump and main switch

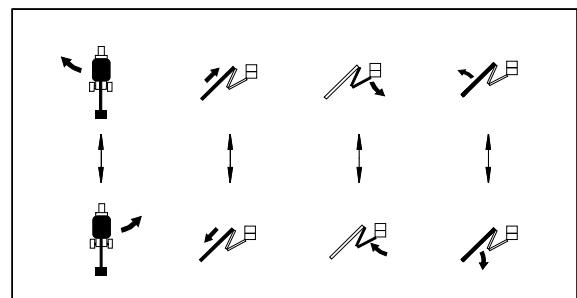

Fig. 42 Label for emergency lowering



6.1 Electrical pump Emergency lowering



Fig. 43 Cover in the basket



Fig. 44 Basket levelling valve



Fig. 45 Emergency kit with bag



Fig 45a Green ball plug valve for emergency lowering



6.1.01 Basket levelling (electrical)

See pictures in the beginning of this chapter 6.1

In emergency lowering situations, the basket levelling has to be done manually.

It is needed to have two persons to adjust the basket.
Person 1 at the ground and Person 2 in the basket.

To level the basket, do as followed:

- Person 1 mounts the emergency handle-**Red** at the basket levelling valve-**Red** (40a) and close the **Red** valve 36a placed on the innerside of turret marked with a red dot sticker.
- Person 1 turns ON the switch for the electrical emergency pump, located next to the main switch.
- Person 2 dismounts the cover in the basket.
- Pull or push the handle for basket levelling to adjust the basket **DOWN** or **UP**.
- When basket leveling is completed, dismount the emergency handle-**Red** (40a) and place it under the cover at the chassis of the platform. Turn back the **Red** valve (36a) to its original position. Placed on the innerside of turret.
- Mount the cover.

WARNING

When activating the Emergency valves at the turret, the safety system of the platform is out of function. It is necessary to operate the platform very carefully and pay highly attention to every move. Failing to do so can cause injury or death.

6.1.02 Emergency lowering Telescopes (electrical)

See pictures in the beginning of this chapter 6.1 and below.



46a

IT IS RECOMMENDED, IF POSSIBLE, TO RETRACT THE TELESCOPES FIRST.

Extend Telescopes

1. Turn the switch for the electrical emergency pump.
2. Mount the **blue** emergency handle at the **blue** emergency valve (40b).
3. Mount the emergency handle without marking at the emergency valve for telescopes (40c), according to the label (42).
4. Move the emergency handle up slowly and the telescopes will extend
5. When emergency lowering is completed, dismount the emergency lowering kit and turn off the emergency pump.

Retract Telescopes

1. Turn the switch for the electrical emergency pump.
2. Mount the emergency handle without marking at the emergency valve for telescopes (40c), according to the label (42).
3. Move the emergency handle down slowly and the telescopes will retract.
4. When emergency lowering is completed, dismount the emergency lowering kit and turn off the emergency pump.

WARNING

When activating the Emergency valves at the turret, the safety system of the platform is out of function. It is necessary to operate the platform very carefully and pay highly attention to every move. Failing to do so can cause injury or death.

6.1.03 Emergency Slewing (electrical)

See pictures in the beginning of this chapter 6.1 and below.

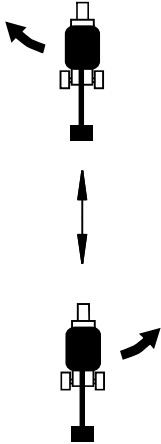

Fig. 46b

WARNING

When activating the Emergency valves at the turret, the safety system of the platform is out of function. It is necessary to operate the platform very carefully and pay highly attention to every move. Failing to do so can cause injury or death.

IT IS RECOMMENDED, IF POSSIBLE, TO RETRACT THE TELESCOPES FIRST.

Levelling clockwise

1. Turn the switch for the electrical emergency pump.
2. Mount the **blue** emergency handle at the **blue** emergency valve.
3. Mount the emergency handle without marking at the emergency valve for levelling, according to the label.
4. Move the emergency controller up slowly and the turret will slew clockwise
5. When emergency lowering is completed, dismount the emergency lowering kit and turn off the emergency pump.

Levelling counter-clockwise

1. Turn the switch for the electrical emergency pump.
2. Mount the **blue** emergency handle at the **blue** emergency valve.
3. Mount the emergency handle without marking at the emergency valve for levelling, according to the label.
4. Move the emergency controller down slowly and the turret will slew counter-clockwise.
5. When emergency lowering is completed, dismount the emergency lowering kit and turn off the emergency pump.



6.1.04 Emergency lowering Link arm (electrical)

See pictures in the beginning of this chapter 6.1 and below



Fig. 47 It is recommended, if possible, to retract the telescopes first.

It is not possible to move the jib and basket jib one by one at emergency lowering.

Fold out the Link-arm system.

1. Turn the switch for the electrical emergency pump.
2. Mount the **blue** emergency handle at the **blue** emergency valve (40b).
3. Mount the emergency handle without marking at the emergency valve for the Link arm system, according to the label (47).
4. Move the emergency handle up slowly and the Link arm system will fold out
5. When emergency lowering is completed, dismantle the emergency lowering kit and turn off the emergency pump.
6. The operator in the basket must re-level the basket

Fold in the Link arm system

1. Turn the switch for the electrical emergency pump.
2. Mount the **red** emergency handle at the **red** emergency valve (40a).
3. Mount the **blue** emergency handle at the **blue** emergency valve (40b).
4. Mount the emergency handle without marking at the emergency valve for the Link arm system, according to the label.
5. Move the emergency handle down slowly and the Link arm system will fold in.
6. When emergency lowering is completed, dismantle the emergency lowering kit and turn off the emergency pump.
7. The operator in the basket must re-level the basket

WARNING

When activating the Emergency valves at the turret, the safety system of the platform is out of function.

It is necessary to operate the platform very carefully and pay highly attention to every move.

Failing to do so can cause injury or death.

6.1.05 Emergency lowering Main boom (electrical)

See pictures in the beginning of this chapter 6.1 and below.

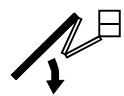

Fig. 48 It is recommended, if possible, to retract the telescopes first.

Main boom up.

1. Turn the switch for the electrical emergency pump.
2. Mount the **red** emergency handle at the **red** emergency valve.
3. Mount the emergency handle without marking at the emergency valve for the Main boom according to the label (48).
4. Move the emergency handle up slowly and the Main boom will move up.
5. When emergency lowering is completed, dismantle the emergency lowering kit and turn off the emergency pump.
6. The operator in the basket must re-level the basket

Main boom down

1. Mount the **blue** emergency handle at the **blue** emergency valve.
2. Mount the **red** emergency handle at the **red** emergency valve.
3. Turn the switch for the electrical emergency pump.
4. Mount the emergency handle without marking at the emergency valve for the Main boom, according to the label.
5. Move the emergency handle down slowly and the Main boom will move down.
6. When emergency lowering is completed, dismantle the emergency lowering kit and turn off the emergency pump.
6. The operator in the basket must re-level the basket

WARNING

When activating the Emergency valves at the turret, the safety system of the platform is out of function. It is necessary to operate the platform very carefully and pay highly attention to every move. Failing to do so can cause injury or death.

**6.2 Emergency lowering
Manual hand pump**

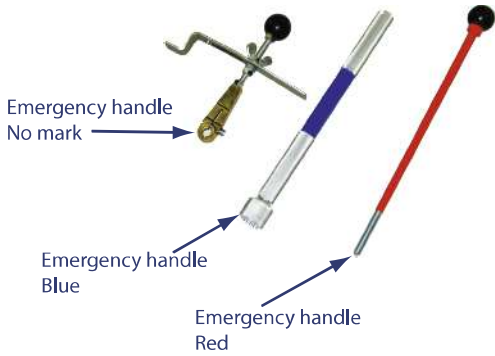

Fig. 49 Emergency tools

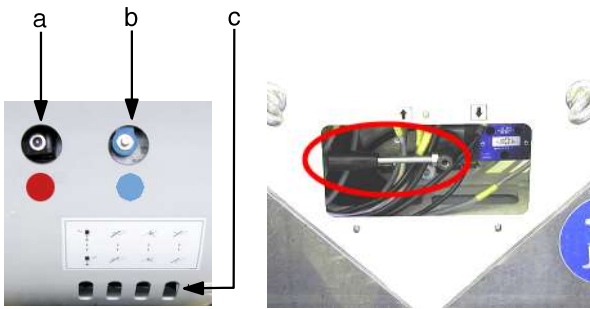

Fig. 50 Emergency controls



Fig. 51 Cover in the basket

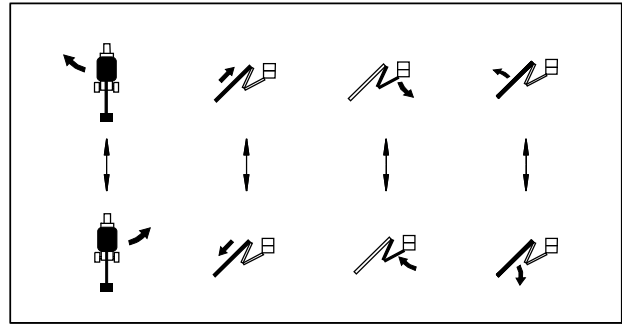

Fig. 52 Emergency label

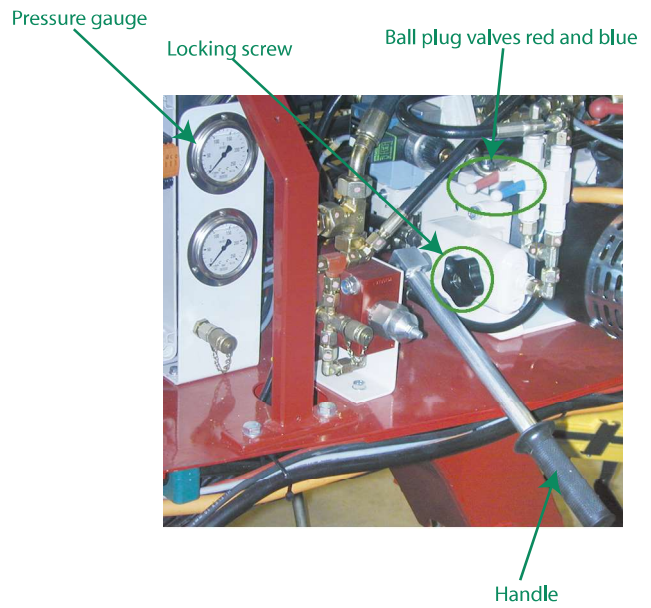

Fig. 53

6.2.01 Basket levelling (Manual)

See pictures in the beginning of this chapter 6.2

In emergency lowering situations, the basket levelling has to be done manually.

Person 1 at the ground and Person 2 in the basket.

To level the basket, do as follows:

1. Person 1 mounts the emergency handle-Red at the basket levelling valve-Red (40a).
2. Person 1 shall use the manual emergency pump.

Person 1 mounts the handle, at the manual hand pump. Open the ball plug valve-Red, close the ball plug valve-Blue and pump with the handle to give oil pressure for the basket levelling function until the red pressure gauge shows app. 160 bar. Then person 1 closes the ball plug valve-Red and opens the ball plug valve-Blue.

When the pressure gauge shows 100-160 bar, and the ball plug valve-Red is closed and the ball plug valve-Blue is open. Person 1 can use the emergency lowering according to the platform functions, while Person 2 levels the basket

3. Person 2 dismounts the cover in the basket.
4. Person 2 activates the handle at the basket-levelling valve.

- Pull the handle for basket levelling to adjust the basket **DOWN**.
- Pushing the handle (**I**) for basket levelling to adjust the basket **UP**.

5. If the basket stops levelling and still needs adjustment, repeat the procedure from 2 to 4

6. Person 1 must pump with the handle for the manual hand pump, simultaneously with Person 2 to pushes the handle for basket levelling.

WARNING

When activating the Emergency valves at the turret, the safety system of the platform is out of function.

It is necessary to operate the platform very carefully and pay highly attention to every move.

Failing to do so can cause injury or death.

7. When basket levelling has completed, mount the cover.

8. Dismount the handle for the manual hand pump and place it under the cover at the chassis.

9. Dismount the emergency controller and place it under the cover at the chassis.



6.2.02 Emergency lowering Telescopes (Manual)

It is needed to have two persons to adjust the basket.

The **green** ball plug valve is only available at platforms taller than 105 ft.

Before starting the manually emergency lowering, close the **green** ball plug valve in the turret. The **green** ball plug valve is normally open (parallel to the pipes).

The valve must be opened again after end of procedure.



IT IS RECOMMENDED, IF POSSIBLE, TO RETRACT THE TELESCOPES FIRST.

See pictures in the beginning of this chapter 6.2 and below.

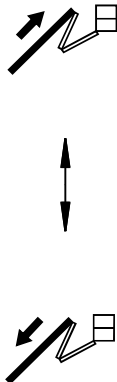

Fig. 55

Extend Telescopes

1. Mount the **blue** emergency handle at the **blue** emergency valve. (40b) Continue to pt. 2

Retract Telescopes

2. Mount the emergency handle without marking at the emergency valve for telescopes, according to the label.
3. Push the emergency handle up for extension, down for retraction and lock it with the thumb screw.
4. Mount the handle located under the cover (right side) on the manual hand pump at the left side of the platform.

5. To give oil pressure for the platform movements, check the ball plug valves, located under the cover at the right side of platform.

The plug valve-**Red** shall be closed.
The plug valve-**Blue** shall be open.

6. Turn the locking screw if mounted, clockwise to close.

7. While pumping the handle the Telescopes extends or retracts.

8. When emergency lowering is completed, dismount the emergency handles and the handle for the emergency pump.

6.2.03 Emergency Slewing (Manual)

IT IS RECOMMENDED, IF POSSIBLE, TO RETRACT THE TELESCOPES FIRST.

Slewing **clockwise or counter-clockwise**

1. Mount the **blue** emergency handle (40b) at the **blue** emergency valve.
2. Mount the emergency handle without marking at the emergency valve for levelling, according to the label.
3. Push the emergency handle up for clockwise slewing, down for counter clockwise slewing, and lock it with the thumb-screw
4. Mount the handle, located under the cover (right side), at the manual hand pump, on the right side of the platform.
5. To give oil pressure for the platform movements, check the ball plug valves, located under the cover at the right side of platform.
 - The ball plug valve-**Red** shall be closed.
 - The ball plug valve-**Blue** shall be open.
6. Make sure, that the locking screw is closed clockwise.
7. While pumping the handle the turret will slew clockwise.
8. When emergency lowering is completed, dismount the emergency handles and the handle for the emergency pump.

6.2.04 Emergency lowering Link arm (Manual)

IT IS RECOMMENDED, IF POSSIBLE, TO RETRACT THE TELESCOPES FIRST.

It is not possible to move the jib and basket jib one by one at emergency lowering.

Fold out the Link-arm system.

1. Mount the **blue** emergency handle (40b) at the **blue** emergency valve.
2. Mount the emergency handle without marking at the emergency valve for levelling, according to the label.
3. Push the emergency handle up for opening the Link arm, down for closing the Link arm, and lock it with the thumb-screw
4. Mount the handle, located under the cover (right side), at the manual hand pump, on the right side of the platform.
5. To give oil pressure for the platform movements, check the ball plug valves, located under the cover at the right side of platform.
 - The ball plug valve-**Red** shall be closed.
 - The ball plug valve-**Blue** shall be open.
6. Make sure, that the locking screw is closed clockwise.
7. While pumping the handle the Link arm will open or close.
8. This brings the basket out of horizontal level, and it is needed to level the basket back to horizontal, according to the basket levelling procedure section 6.2.01
9. If necessary repeat the procedure, and pay attention to the level of the basket.
10. When emergency lowering is completed, dismount the emergency handles and the handle for the emergency pump.

6.2.05 Emergency lowering Main boom (Manual)

IT IS RECOMMENDED, IF POSSIBLE, TO RETRACT THE TELESCOPES FIRST.

Main boom up

1. Mount the emergency controller without marking at the emergency valve for the Main boom, according to the label.
Mount the **red** handle at the **red** emergency valve.

OR

Main boom down

1. Mount the **blue** emergency handle at the **blue** emergency valve and the **red** emergency handle at the **red** emergency valve.

THEN

2. Push the emergency handle up to move the main boom up push it down to move main boom down, and lock it with the thumb screw
3. Mount the handle, located under the cover at the chassis, at the manual hand pump, at the chassis.
4. To give oil pressure for the platform movements, check the ball plug valves, located under the cover at the chassis.
 - The ball plug valve-**Red** shall be closed.
 - The ball plug valve-**Blue** shall be open.
5. Make sure, that the locking screw is closed clockwise.
6. While pumping the handle the Main boom moves up or down.
7. This brings the basket out of horizontal level, and it is needed to level the basket back to horizontal, according to the basket levelling procedure section 6.2.01
8. If necessary repeat the procedure, and pay attention to the level of the basket.
9. When emergency lowering is completed, dismount the emergency handles and the handle for the emergency pump.

7.0 After end using the platform

In this chapter you will find:

- **After end using the platform**

7.0 After end using the platform

Control the platform from the Chassis control panel (suppl. A).

1. Slew the turret until the **green** indicator light comes on (#c).
The main boom is now in centre.
2. Retract the telescopes to the cradle.
3. Fold in the link arm system.
4. Move the main boom down.

CAUTION

Do not let the basket hit the ground. This can cause structural damage to the platform.

5. Dismount the basket if necessary.

6. Raise the outriggers, and lock them in stowed **Red** position if necessary.

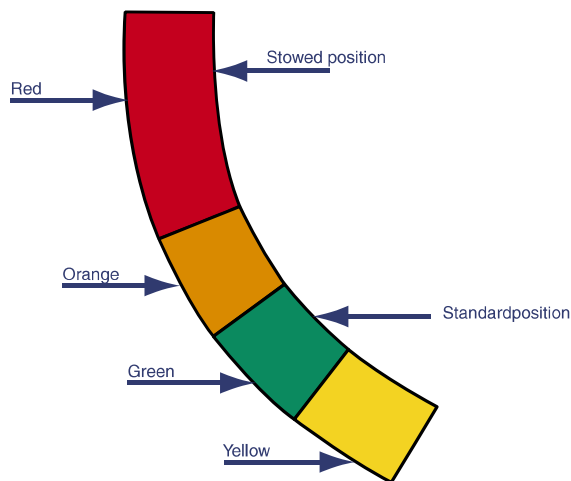
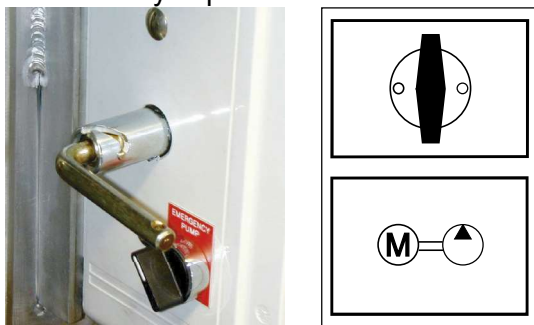

Fig. 56

7. Turn off the Key selector switch #u and the main battery separator switch.



If lithium model it is very important to turn off key selector switch also.

An audio signal will sound if Main battery separator switch is “off” and the key selector switch is not “off”.

CAUTION

The **red** stability lights at the outriggers **MUST** come on when the outriggers are raised from the ground.

Failure in the safety system can cause injury or death.

Call authorised service centre immediately.

CAUTION

When the platform is transported, the outriggers must be raised minimum 5 cm/2 inch. from the ground.



8.0 Transporting the platform

In this chapter you will find:

- **Transporting the platform**
- **Strapping**

8.0 Transporting the platform

1. Transportation over longer distances can be done by truck, trailer, etc.
2. The platform can load and off load itself by using the outriggers.
3. Lock the outriggers in standard position-**green** (45° to the chassis)

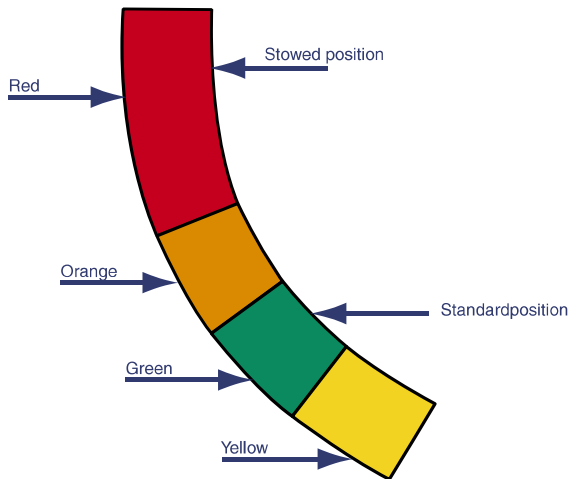

Fig. 57

4. Loading or unloading: Lower the outriggers to the ground, see photos until the platform is lifted enough to place a truck under it or drive away from the platform. Avoid damaging the outriggers.

5. Lift the outriggers completely from the ground and place the outriggers in **Red** position. (Stowed). This in order to reach the stowed dimensions according to the General data.

CAUTION

It is important that all 4 outriggers have the same load when loading, unloading and during operation. Notice the **red** lights on the outriggers. Always keep the platform horizontal while loading and unloading.

Activate the outriggers 2 by 2, front and rear.

WARNING

Do not set up the platform when the outriggers are in **Red** position (Stowed). This is **ONLY** a transport position.



Fig. 58 Platform lifted by the outriggers



Fig. 59 Truck under platform

6. When the platform is placed on a truck, it **MUST** be securely strapped. Please follow the procedure. The platform must be strapped in both front and rear end and from both sides (left and right). If possible strap the platform at the middle also.
 - a. Strap the platform in the rear end by the fixing points (Strap 1 - fig 60), and to a fixing points at the truck (Strap 2 - fig. 61). Remember to strap the platform in both sides.



Fig. 60 Strap 1



Fig. 62 Strap 3



Fig. 63 Strap 4 with Rubber mat



Fig. 61 Strap 2

b. The front end can be strapped in two different ways. From the fixing points at the turret (Strap 3 - **fig. 62**), or from the fixing points inside the turret (strap 4 - **fig. 63**) to a fixing point at the truck (strap 2 - **fig. 62**). When using the fixing points **ALWAYS** remember to protect the turret with a piece of rubber (Strap 4 with rubber mat - **fig. 62**) or likewise.

c. From the fixing point at the front end of the belts and to a fixing point at the truck (Strap 5 - **fig. 64**). Or from the fixing point at the rear end of the platform to a fixing point at the truck (Strap 6 - **fig. 65**)



Fig 64 Strap 5



Fig. 65 Strap 6

7. After end transportation, unload the platform using the outriggers or ramp.

Transporting the Falcon

Strapping the Falcon for Transportation

Recommended strapping illustrated below:

1. Fasten straps across turret
2. Fasten straps through the eyes on each outrigger knee joint.
3. Fasten straps through the eyes on each side of boom at the basket end.

In order to minimize wear and tear on the lift due to strapping:

Place blocks under the sandwich prior to strapping down the lift.

Use straps only and not chains.

Insert cloth or other padding between the lift and straps in the areas where the straps come in contact with the lift.

Failure to follow these instructions may result in severe damages to the lift.

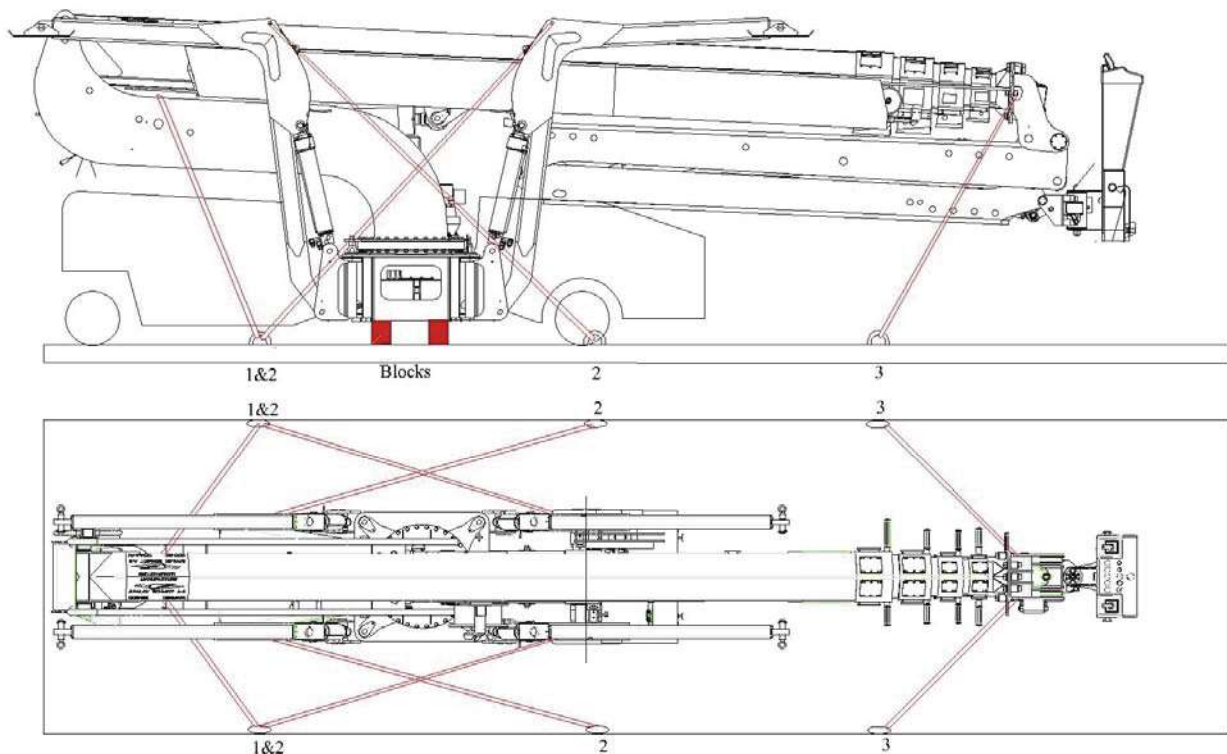

Preparing the Basket for transportation



When transporting the lift as shown above, the basket should be removed from the lift and strapped separately. To prevent damage to the casters, the basket should be raised off the ground onto a wooden block.

9.0 Safety Instructions

In this chapter you will find:

- **Safety Instruction**



9.0 Safety Instructions

When using the platform you must always make sure that the necessary stability is maintained. The safety system (Cut out system) secures that the maximum reachable load according to the outreach is limited, by the chosen positions of the outriggers.

When maximum capacity has been reached, a red "Stability Indicator light" comes on at the Chassis control panel (suppl. A), at the Basket control panel (Suppl. B) and on the outriggers with minimum load. This indicates that the "Cut-Out" zone has been reached.

Simultaneously, all movements that could reduce stability further are stopped. Only movements that will reduce the working radius and centre the load are permitted: **"RETRACT TELESCOPE"** and **"MAIN BOOM UP"**.

Safe work with the platform demands that the instructions for use and maintenance are followed, and that the daily inspection check is performed prior to the operation of the platform.

Check that all the labels are easily readable.

The platform must be on hard flat ground and level.

Work has to be stopped when wind exceeds 28 mph in gusts. (Wind force 6 after Beaufort).

When working on public roads or places, the working area must be corded off and surrounded by signs of flashing yellow lights according to the existing laws.

When the platform is left unattended, it must be secured against unauthorised use.

Work near high voltage installations is prohibited.
The platform is NOT insulated.

According to the CE- and national prescriptions only persons with the necessary instructions may use the platform.

When the platform is used for welding work, the platform has to be without power and the outriggers must be placed on rubber mats.

Do not use the platform without reading and following all instructions carefully.
Failure due to incorrect operating procedures and safety instructions can cause injury or death.

10.0 Inspection and maintenance

Inspection and maintenance

Perform inspection and maintenance for the diesel engine (Option), generator (Option) etc. according to the Operators/Maintenance manual for these parts.

10.1 Daily inspection and maintenance check

1. If the check should not be performed with the following result, the platform may not be used before all malfunctions are repaired.
2. With the outriggers lifted off the ground, check that the red „Stability Indicator lights“ is on at all outriggers, and the red **“Stability Indicator light”** at the Basket control panel (Suppl. B) and at the Chassis control panel (suppl. A) are on.
3. When the platform has been set up and before operations start, please check that when maximum outreach is achieved, one or two of the red Stability Indicator light(s) on the outrigger(s) comes on together with the **“Stability Indicator light”** at the Basket controlpanel (Suppl. B) and at the Chassis control panel (suppl. A). The only functions free in this situation shall be **“RETRACT TELESCOPE”** and **“MAIN BOOM UP”** until the Stability Indicator lights are off.
4. Check the charge indicator for battery state.
5. Check that the emergency stop disables all functions of platform.
6. Check the platform for any defects such as: damaged cables or chains, hydraulic leaks, loose wiring, structural damage, damaged basket mounting brackets, tire damage, etc.

10.2 Weekly inspection and maintenance check

1. Tighten the crawler belts, according to section 10.7.
2. Visual inspection of all axle locking plate bolts.
To control all links on the double jib (Link arm), it has to be folded out and brought in position straight to the main arm.

10.3 Monthly inspection and maintenance check

1. Check the oil level in the hydraulic tank, and refill as required.

In this chapter you will find:

- Inspection and maintenance
- Daily inspection and maintenance check
- Monthly inspection and maintenance check
- Yearly inspection and maintenance check
- Control of the chains
- Inspection and maintenance of stability system
- Spare parts modification
- Tightening of the crawler belts
- Lubrication diagram

2. Lubricating according to the lubrication diagram.
3. Check all cylinders for tight fit and the valves and oil pipes for leaks.
4. Tighten the wheels according to the specification Nm.

Torque and Maintenance Intervals

Torque Recommendation (Table 1)

Bolts and Specialty Fasteners							
UNIT	M12	M14	M16	M20	M24	M30	M36
(Nm)	70	115	175	350	500	600	700
(Lbft)	52	85	129	158	369	443	516

Nuts: Standard Height							
UNIT	M12	M14	M16	M20	M24	M30	M36
(Nm)	65	115	175	250	350	500	600
(Lbft)	48	85	129	184	258	369	443

Nuts: Low Height							
UNIT	M12		M16	M20	M24	M30	M36
(Nm)	60		125	200	275	350	
(Lbft)	44		92	148	203	258	

Spanner Nuts							
UNIT	M17	M25	M35	M45	M55	M65	M76
(Nm)	50	120	250	500	600	700	800
(Lbft)	37	89	184	369	443	516	590

IMPORTANT: RE-TORQUE IS AN INTRICATE PART OF THE INSTALLATION AND CRUCIAL TO THE SUCCESS OF THE REPAIR. Make sure to follow the torque schedule in Table 2

IMPORTANT: CHECK THE TORQUE AT REGULAR SERVICE INTERVALS.
Apply appropriate torque according to Table 1. Tighten until the torque wrench "clicks out" on setting

IMPORTANT: Proper greasing of your machine pivots are crucial for the functioning and durability of the Expander system. We strongly recommend using grease with 3-5% molybdenum disulfide, which allows much less wear and gives increased load carrying capability.

Torque Schedule (Table 2)

<p>Hours Of Operation After 1 hour After 3 hours After 10 hours or 1 day * After 40 hours or 4 days *</p>	<p>* When you re-torque and the wrench "clicks out" on setting without adding additional torque, you have successfully seated the expansion sleeves. If the expansion sleeves have not seated within one week of operation, call your local dealer for instructions.</p>
--	---



10.4 Yearly inspection and maintenance check

1. The platform must go through an annual inspection performed by a certified aerial lift company.

The annual inspection must check all lifting and supporting devices, chassis etc. for wear and tear or any defects. The platform must be checked for loose wiring and any part that need to be tightened or replaced due to normal wear and tear, damage or manufacturers defect.

All inspections and repairs must be recorded and kept in the machine file.

2. Lubrication according to the lubrication diagram.
(See section 10.9)

3. Check that turret bearing bolts has torque to specifications shown in the NM tabel.

4. Check all parts of the platform for corrosion, cracks and other damages.

5. Control of the chains:
Wear on the chains must be controlled over 10 chain links.
By controlling the length between 11 spikes.
Maximum allowable wear is 2% over 10 chain links.

Platform model	Bolts in outer circle (top)	Bolts in inner circle (bottom)
FS75	M12/90 Nm.	M12/90 Nm.
FS95	M12/90 Nm.	M12/90 Nm.
FS95C	M12/90 Nm.	M12/90 Nm.
FS290	M14/160 Nm.	M14/160 Nm.
FS290C	M14/ 160 Nm	M14/160 Nm.
FS105	M14/160 Nm.	M14/160 Nm.
FS105C	M14/160 Nm.	M14/160 Nm.
FS108Z	M16/215 Nm.	M16/215 Nm.
FS121	M16/ 240 Nm.	M16/ 240 Nm.
FS121C	M16/ 240 Nm.	M16/ 240 Nm.
FS138	M16/ 240 Nm.	M16/ 240 Nm.
FS138C	M16/ 240 Nm.	M16/ 240 Nm.
FS170C	M20/ 480 Nm.	M20/ 480 Nm.

Nm Table

Chain groups	Nom. length 1 link (mm)	Nom. length 10 Links (mm)	Nom. length with 2% wear (mm)
1/2" chain (12. series)	12,7	127	129,5
5/8" chain (15. series)	15,875	158,75	162
3/4" chain (19. series)	19,05	190,5	194
1" chain (25. series)	25,4	254	259

1 inch = 25.4mm

10.5 Inspection and maintenance of stability system

To perform check of the stability system, a scale, with a capacity at minimum 6600 lb is required. The minimum readout tolerance of the scale shall be no more than 11 lb.

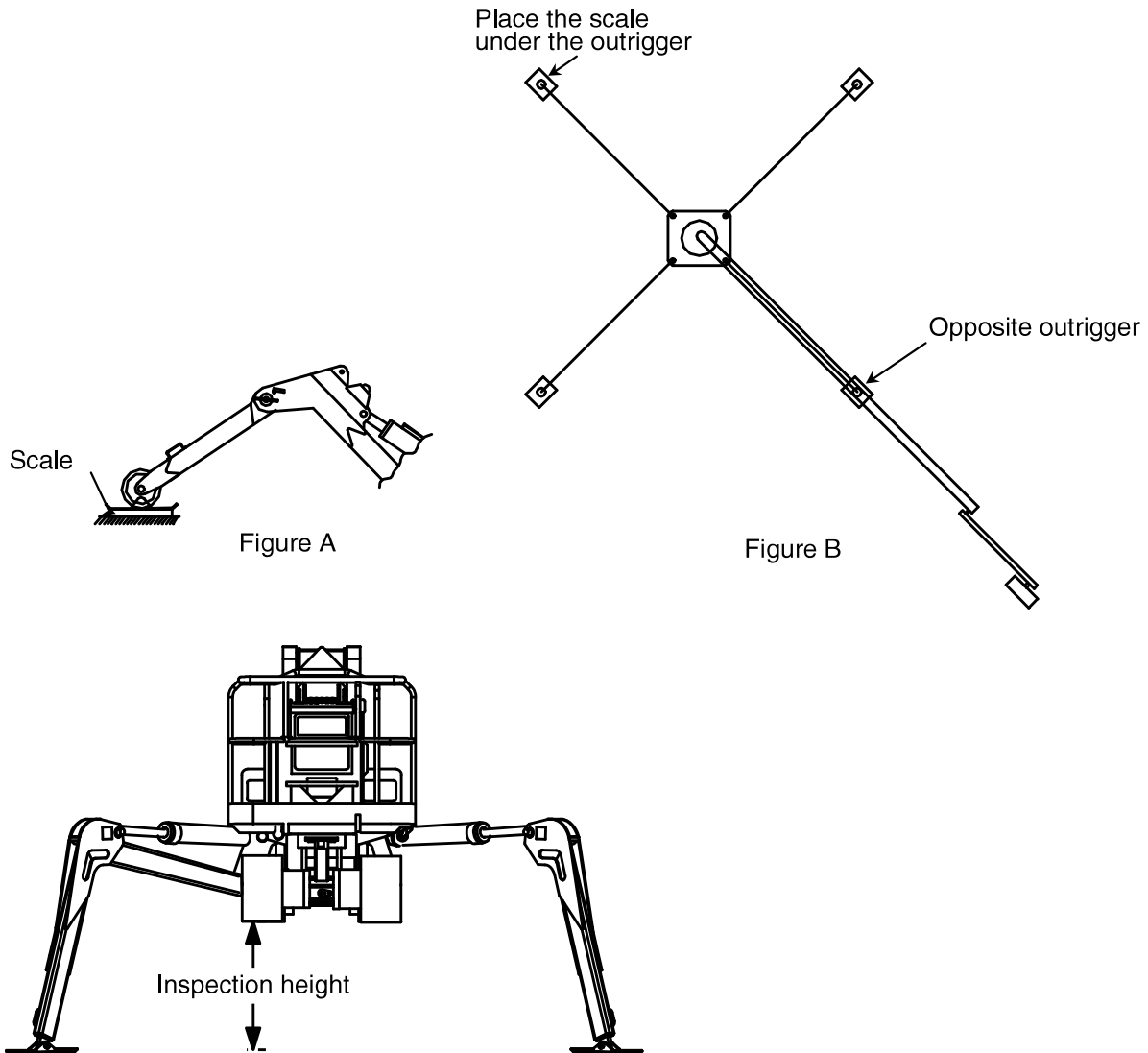

Place the scale under one of the outriggers.
See figure A.
The outriggers must be in standard position.

Raise the platform to inspection height 2 ft
telescope out over the opposite outrigger
until the red lights at the outrigger at the scale
comes on.

(See figure B)

See table to see accurate allowed weight

WARNING

If the **red** lights do not light up or the scale does not show allowed weight according to table column A, call an authorized service centre immediately.

Failure in the safety system can result in injury or death.

Retract the telescopes until the light on the outrigger at the scale turns off. The scale may maximum show allowed weight according to table when the **red** light turns off.
Repeat this procedure on all 4 outriggers.

WARNING

If the scale shows more than maximum allowed weight according to table column B, call an authorized service centre immediately.

Failure in the safety system can result in injury or death.

Scale for model	A Kg for lights to light up	B Maximum weight when light turns off
FS95	650 lb/716 lb*	992 lb/1157 lb*
FS105	716 lb	1157 lb
FS121	1653 lb	2335 lb
FS121C	1819 lb	2646 lb
FS138	1764 lb	2646 lb
FS138C	1819 lb	2646 lb
FS170C	3086 lb	4300 lb

**Hatz Diesel or Honda generator + 4 extra batteries*

10.6 Spare parts modification

Spare parts are listed in separate spare parts catalogue.
 Do not repair with unauthorised components.
 Do not make any modifications without prior written approval.

**10.7 Tightening of the crawler belts
 Platforms with 1 set of belts**

Tighten the crawler belts once a week with lubrication grease (Type Texaco Multifak EP-2).
 Check the adjustment by the nut for the tension roller.

1. Dismount the cover over the grease nipple. (1 nipple on each side of the platform).



Fig. 66 The nut for the tension roller is placed here

2. Tighten the tension roller by a grease gun



Fig. 67 Grease gun on grease nipple for the tension roller



Fig. 68 Nut – Crawler belts NOT tightened

3. When the crawler belts are tightened correctly, there must be a distance between nut and the rear plate of app. 0,5-1mm.

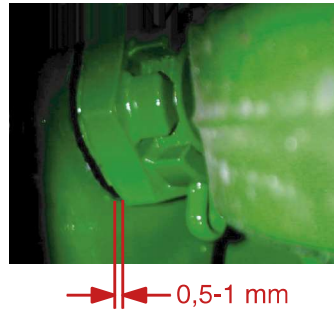

Fig. 69 Nut – Crawler belts tightened

4. It can be difficult to see the nut. Use a mirror.



Fig. 70 Placement of mirror

10.7.1 Tightening the Crawler belts

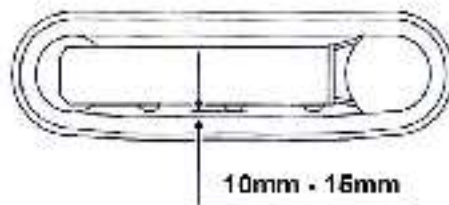

Fig. 70a distance for correct tightening of belts
 With the belts raised from the ground the belts deflection must be around 10mm - 15 mm as shown on fig. 70a.
 The tesion is performed with a grease gun as showed on fig. 67.

10.8 Tightening of the crawler belts Platforms with 2 set of belts

Tighten the crawler belts once a week with lubrication grease (Type Texaco Multifak EP-2). Check the adjustment by the nut for the tension roller.

1. Dismount the covers over the grease nipple. (2 nipples on each side of the platform).



Fig. 66a The nipples for the tension roller is placed here

2. Tighten the tension roller by a grease gun equipped with a pressure gauge. Use the adapter between the nipple and the grease gun. There is one type of adapter for the front belts and another type for the rear belts.

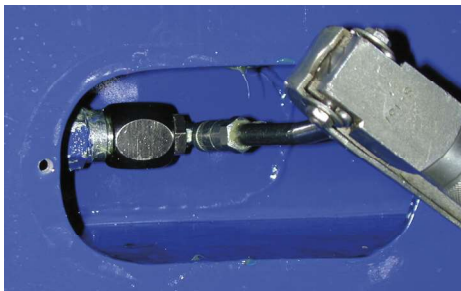

Fig. 67a Grease gun on grease nipple with adaptor for the tension roller



Fig. 68a Pressure gauge on Grease gun

3. When the crawler belts are tightened correctly the pressure must show max. 150 bar in the front belts and max. 200 bar in the rear belts

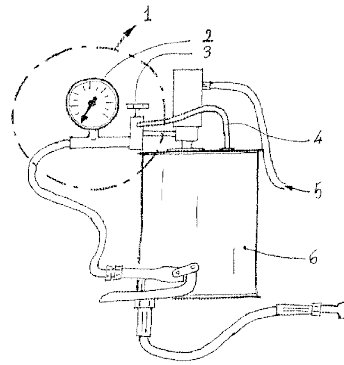
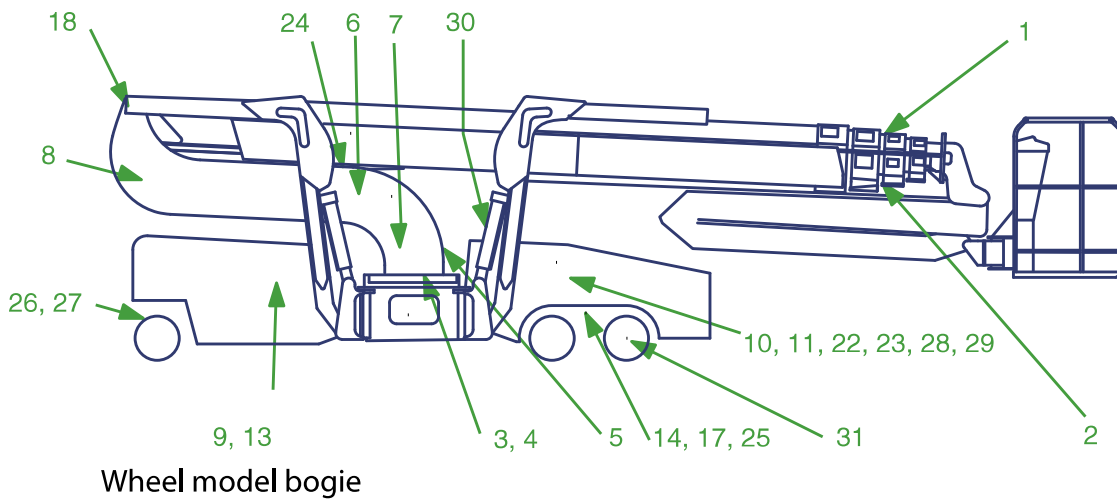
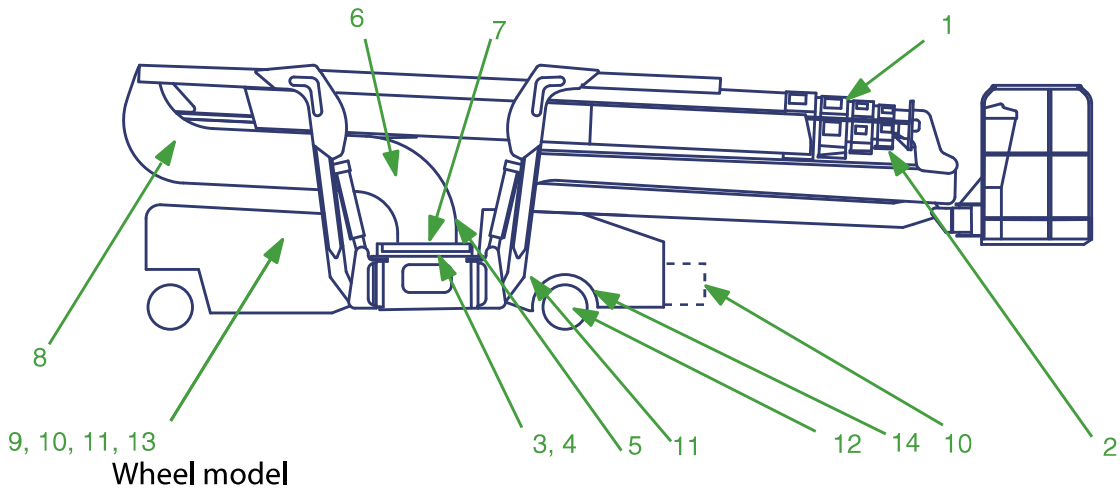

Fig. 69a Track tightening kit

1	Track tightening kit
2	Pressure gauge
3	Pressure regulator
4	Grease drain
5	Compressed air
6	Grease container

10.9 Lubrication diagram



Lubrication diagram

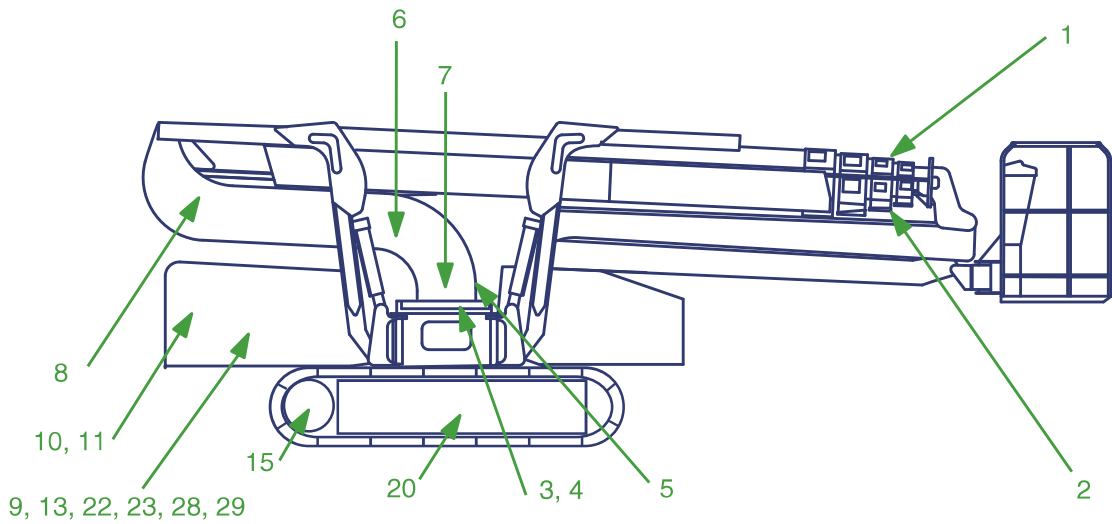

Crawler model

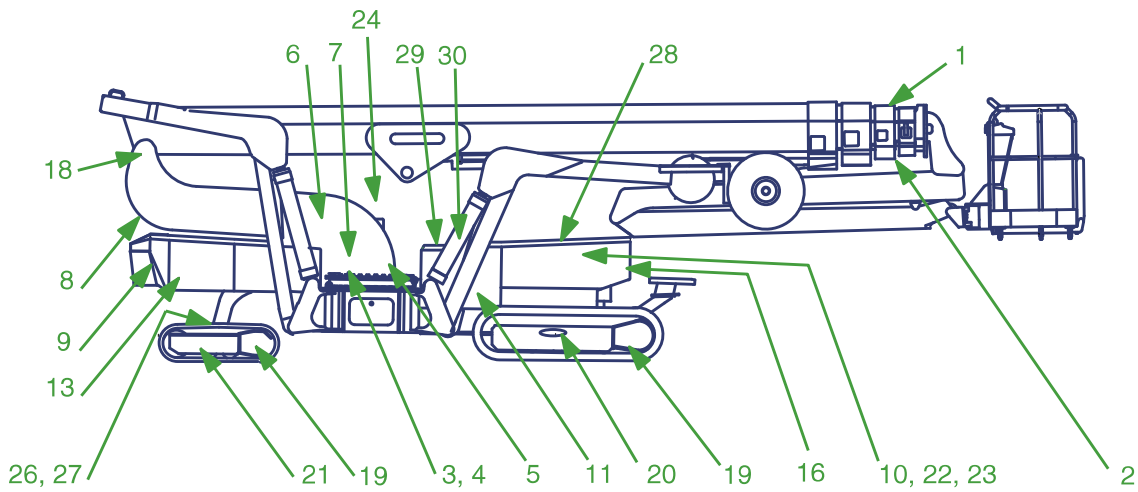

Crawler model double track



Spot:	Place for servicing	No. of spots	Type of maintenance	Lubrication etc.	Quantity/ GAL	Service interval/ hours
1	Telescopes	2-7	Grease	Texaco Multifak EP2		Once a year
2	Chains in main boom	9-15 chains	Lubrication spray	Würth 0890 105 51-B		Once a year
3	Race ring	2-4	Grease	Texaco Multifak EP2		50
4	Race ring teeth	All	Grease	Texaco Multifak EP2		50
5	Swivel gear	1	Oil	Texaco geartex EP-C SAE 80W/90	0.2	*
6	Hydraulic oil in tank	1	Oil	Texaco HDZ 32Rando	13-29	**
7	Suction strainer in oil tank	1				**
8	Return filter	1				Once a year
9	Pressure filter	1				Once a year
10	Fuel tank (option)		***	***		Daily
11	Oil for engine (option)		***	***		***
12	Rear wheel brake	2	Oil	Texaco ursa Super SAE10	0,02 /gear	*
13	Balance filter		Change			Once a year
14	Guides for gauge	2	Grease	Texaco Multifak EP2		50
15	Gear for crawler tracks	2	Oil	Texaco geartex EP-C SAE 80W/90		****
16	Return filter for crawler tracks	1				Yearly
17	Bogie	2	Grease	Texaco Multifak EP2		50
18	Axle for main boom	2	Grease	Texaco Multifak EP2		50
19	Track gear	4	Oil	Texaco Meropa 150	0,13	****
20	Tightening crawler tracks	2	Grease	Texaco Multifak EP2		Weekly
21	Tightening crawler tracks front	2	Grease	Texaco Multifak EP2		Weekly
22	Fuel filter	1	***	***	***	***
23	Oil filter	1	***	***	***	***
24	Main boom cylinder	2	Grease	Texaco Multifak EP2		50
25	Gauge change cylinder	4	Grease	Texaco Multifak EP2		50
26	Front wheel bearing	2	Grease	Texaco Multifak EP2		50
27	Front wheel cylinder	3	Grease	Texaco Multifak EP2		50
28	Air filter	1	***	***	***	***
29	Cooling liquid	1	***	***	***	***
30	Axle for outrigger	8	Grease	Texaco Multifak EP2		50
31	Rear wheel gear	2	Oil	Texaco geartex EP-C SAE 80W/90	0,13/gear	*

* = Once a year check the oil and refill as required. Replace the oil when it is needed.

** = Replace as required

*** = For lubrication and maintenance of engine and/or extra equipment, please follow the instructions in the Maintenance- or Operators Manual specified for those parts.

**** = First time after 500 hours, after this for every 1000 hours or once a year.

(1) = See section 10.7

Appendix

In this chapter you will find:

- **Appendix A: Sliding tracks**
- **Appendix B: Key switch at the turret**
- **Appendix C: Outriggers with hinged joints**
- **Appendix D: Reduced working height**
- **Appendix E: Twin wheels**

Appendix A: Sliding tracks for the outriggers on the Platform (Option).

The platform can optionally be equipped with sliding tracks for the outriggers to protect sensible surfaces against marks and scratches.

The sliding tracks may ONLY be mounted, when the outriggers are turned away from the chassis and secured in position, **green**, **orange** or **yellow**.

CAUTION

Mounting of the sliding tracks with the outriggers in stowed position (Red) can cause structural damage to the platform.

1. Turn the outriggers away from the platform.
2. Secure the outriggers to the chassis frame in position **green**, **orange** or **yellow** and secure the outriggers with the locking bolt.
3. Mount the outrigger footplates according to the operator's manual.
4. Mount the sliding tracks at the outrigger footplates by hand.
5. Lower the outriggers to the ground according to operator's manual. The outriggers will now slide at the surface.
6. When the platform has to be moved, lift the outriggers from the ground, according to the operators manual, so that the sliding track no longer have contact with the ground. Move the platform and lower the outriggers.



Sliding track mounted at the outrigger

Appendix B: Key switch at the turret for operating the chassis without main boom in cradle (Option)

WARNING

Never use this function with wheels in narrow position, always make sure that rear wheels are set in maximum wide position before engaging this feature. Never raise the boom above 7 ft in this mode, measured from floor to end of main boom.

Always use maximum care when driving the unit in this position and only use where absolutely necessary. As soon as surroundings permit driving the lift in normal position (secured in the cradle) lower the main boom as per below instructions.

Always take basket off before switching to this mode.

Never work, place or put anybody or anything in the basket in this mode, this is strictly a transportation mode to pass obstacles on the floor that not otherwise can be passed.

Key-switch 1 – Driving the platform with the main boom in raised position.

1. Activate the electrical emergency pump next to the main switch
2. Move the main boom up by the emergency valves, according to the instructions about emergency operation of the main boom in the operator's manual.
3. Turn the key-switch (1) at the turret to the right.. It is now possible to drive the platform with the main boom in raised position.

WARNING

Driving the platform with the main boom in raised position is only allowed on horizontal surface. Drive slowly and pay attention to the balance of the platform. Driving the platform on non-horizontal surfaces, can cause the platform to turn over and result in personnel and/or material injury or death.

4. Whenever possible drive the platform with the main boom in stowed position (in the cradle). Lower the main boom by the emergency lowering valves, according to the instructions about emergency operation of the main boom in the operator's manual.
5. Turn the key-switch (1) at the turret to the left and remove the key, store key in a safe place.

WARNING

Do NOT use any platform functions, when the key-switch is turned to the right.

This is a feature that requires maximum care, as the lift is very unstable in this mode, and can tip over if handled incorrectly.



**Appendix C: Outriggers with hinged joints.
(Option).**

1. Loosen the hinged joint so the teeth are fully apart, (notice the small hinged safety handle, which prevents the hinged joint from loosening when tightened), and check that the lower part of the outrigger hangs freely.

2. Open/turn the lower part of each outrigger, at least to the standard position, and tighten the hinged joint fully by the hand wheel. Turn the small safety handle into position between the two plates of each of the upper and lower part of the outrigger, to secure the hinged joint against loosening/opening.

Marking for optimized position of hinged joint at the outrigger.

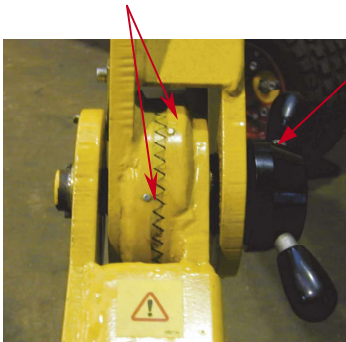

Hand wheel

Hinged joint in optimized position

Marking for standard position of hinged joint at the outrigger

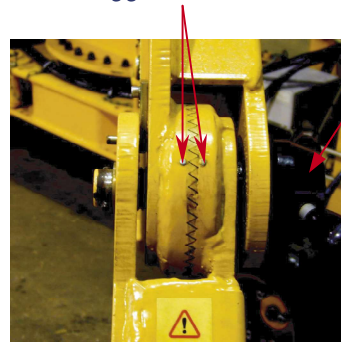

Hand wheel

Hinged joint in standard position



*Safety handle – Open
Unsafe!*



*Safety handle – closed.
Safe!*

Appendix D: Reduced working height (Option)

Turnable key-switch – Reduction of the working height.

If it is necessary to reduce the working height. Turn the key-switch (2) at the turret to the right and remove the key.

The working height of the platform is now reduced.

To change the working height to the original working height, place the key in the turnable key-switch and turn the key to the left.



Appendix E: Twin wheels

Important!

Outriggers may NOT be placed in narrow position at the rear end if twin wheels are mounted.

Outriggers will collide with the wheels and cause damage to them.



